

# Lantech

---

## T(P)GS-5208GF Series

8 10/100/1000T X-coded + 2 1000FX Q-ODC L2+ (w/8 PoE at/af)  
EN50155 Managed Ethernet Switch

## T(P)GS-5010T Series

10 10/100/1000T X-coded (w/8 PoE at/af) EN50155 Managed  
Ethernet Switch

## T(P)GS-5008T Series

8 10/100/1000T X-coded EN50155 L2+ (8 PoE at/af) Managed  
Ethernet Switch

### User Manual (Hardware)



V1.01  
NOV. 2024  
RP-001-31

## Approval Information

<b>Version 1.01</b>	<b>Name</b>	<b>Title</b>	<b>Date</b>
<b>Author</b>	Greg Tsai	Marketing	2024.11.20
<b>Verifier</b>	Jacky Chou	HW QA	2024.11.20
<b>Approver</b>	Thomas Lee	RD head	2024.11.20

<b>Version</b>	<b>Date</b>	<b>Content of Modification</b>	<b>Author(s)</b>
<b>V1.00</b>	2022.10.28		Greg Tsai
<b>V1.01</b>	2024.11.20	Update on PoE Budget Usage Guidelines	Greg Tsai

## Recommendation for Shielded network cables

STP cables have additional shielding material that is used to reduce external interference. The shield also reduces the emission at any point in the path of the cable. Our recommendation is to deploy an STP network cable in demanding electrical environments. Examples of demanding indoor environments are where the network cable is located in parallel with electrical mains supply cables or where large inductive loads such as motors or contactors are in close vicinity to the camera or its cable. It is also mandatory to use an STP cable where the power device (like IP camera) is used outdoors or where the network cable is routed outdoors.

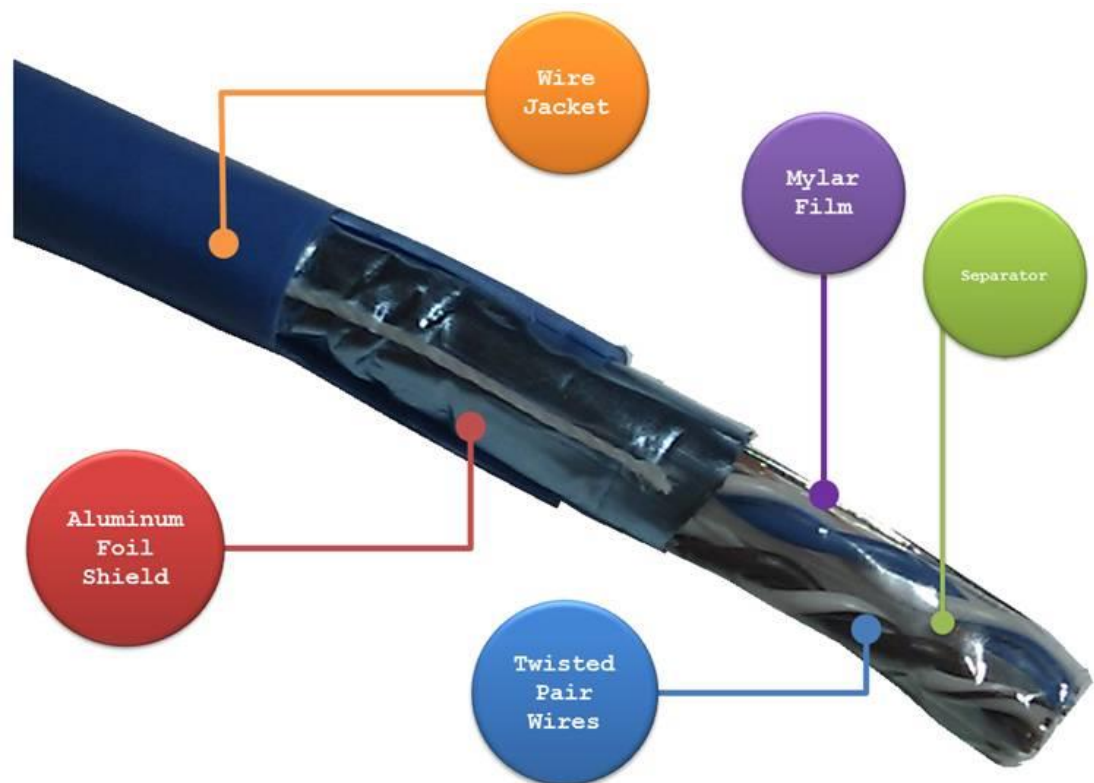

## **Important Notice**

Lantech Communications Global, Inc. reserves the right to modify the equipment, its specification or this manual without prior notice, in the interest of improving performance, reliability, or servicing. At the time of publication all data is correct for the operation of the equipment at the voltage and/or temperature referred to. Performance *data* indicates typical values related to the particular product.

No part of this documentation or information supplied may be divulged to any third party without the express written consent of Lantech Communications Global Inc. Products offered may contain software which is proprietary to Lantech Communications Global Inc. The offer or supply of these products and services does not include or infer any transfer of ownership.

## **Interference Issues**

This Equipment has been tested and found to comply with the limits for a Class A digital device, pursuant to Part 15 of the FCC rules. These limits are designed to provide reasonable protection against harmful interference in a commercial or industrial installation. This equipment generates, uses, and can radiate radio frequency energy. It may cause harmful interference to radio communications if the equipment is not installed and used in accordance with the instructions.

## **FCC Warning**

This Equipment has been tested and found to comply with the limits for a Class-A digital device, pursuant to Part 15 of the FCC rules. These limits are designed to provide reasonable protection against harmful interference in a residential installation. This equipment generates, uses, and can radiate radio frequency energy. It may cause harmful interference to radio communications if the equipment is not installed and used in accordance with the instructions. However, there is no guarantee that interference will not occur in a particular installation. If this equipment does cause harmful interference to radio or television reception, which can be determined by turning the equipment off and on, the user is encouraged to try to correct the interference by one or more of the following measures:

- Reorient or relocate the receiving antenna.
- Increase the separation between the equipment and receiver.
- Connect the equipment into an outlet on a circuit different from that to which the receiver is connected.
- Consult the dealer or an experienced radio/TV technician for help.

## **CE Mark Warning**

This is a Class-A product. In a domestic environment this product may cause radio interference in which case the user may be required to take adequate measures.

# **Content**

<b>Chapter 1 Introduction.....</b>	<b>6</b>
<b>Chapter 2 Hardware Description .....</b>	<b>7</b>
2.1 Physical Dimension.....	7
2.2 Package Content:.....	12
2.3 IP Protection.....	13
2.4 LED Indicators.....	16
<b>Chapter 3 Hardware Installation .....</b>	<b>18</b>
<b>Chapter 4 Console Management .....</b>	<b>27</b>
4.1. Connecting to the Console Port .....	27
4.2. Login in the Console Interface .....	27

# Chapter 1 Introduction

---

Lantech T(P)GS-5208GF / T(P)GS-5010T / T(P)GS-5008T (IP54) are high performance L2+ All Gigabit Ethernet switches (w/8 PoE at/af injectors up to 30W at M12 X-coded) providing L2 wire speed and advanced security function for network aggregation deployment.

	<b>10/100/1000T Copper</b>	<b>1G Q-ODC Fiber</b>	<b>PoE</b>
<b>TPGS-5208GF</b>	8	2	8
<b>TGS-5208GF</b>	8	2	
<b>TPGS-5010T</b>	10		8
<b>TGS-5010T</b>	10		
<b>TPGS-5008T</b>	8		8
<b>TGS-5008T</b>	8		

# Chapter 2 Hardware Description

In this paragraph, it will describe the Industrial switch's hardware spec, port, cabling information, and wiring installation.

A battery is inside the device to maintain the RTC function with estimated battery life of 10 years. The lost of battery power will only effect the RTC function. \*Unless otherwise specified.

## 2.1 Physical Dimension

### T(P)GS-5208GF

Aluminum case. IP-54, 235mm (W) x 195mm (H) x 96.2mm (D)

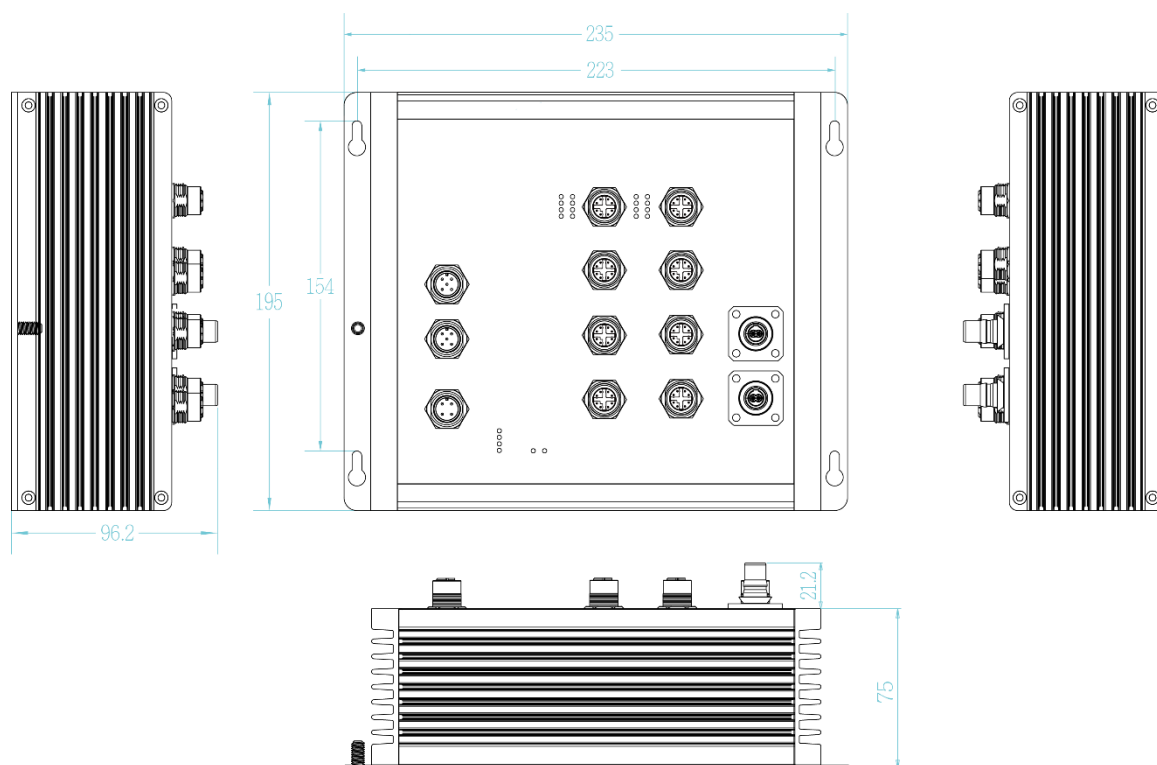



### T(P)GS-5010T

Aluminum case. IP-54, 235mm (W) x 195mm (H) x 89.5mm (D)

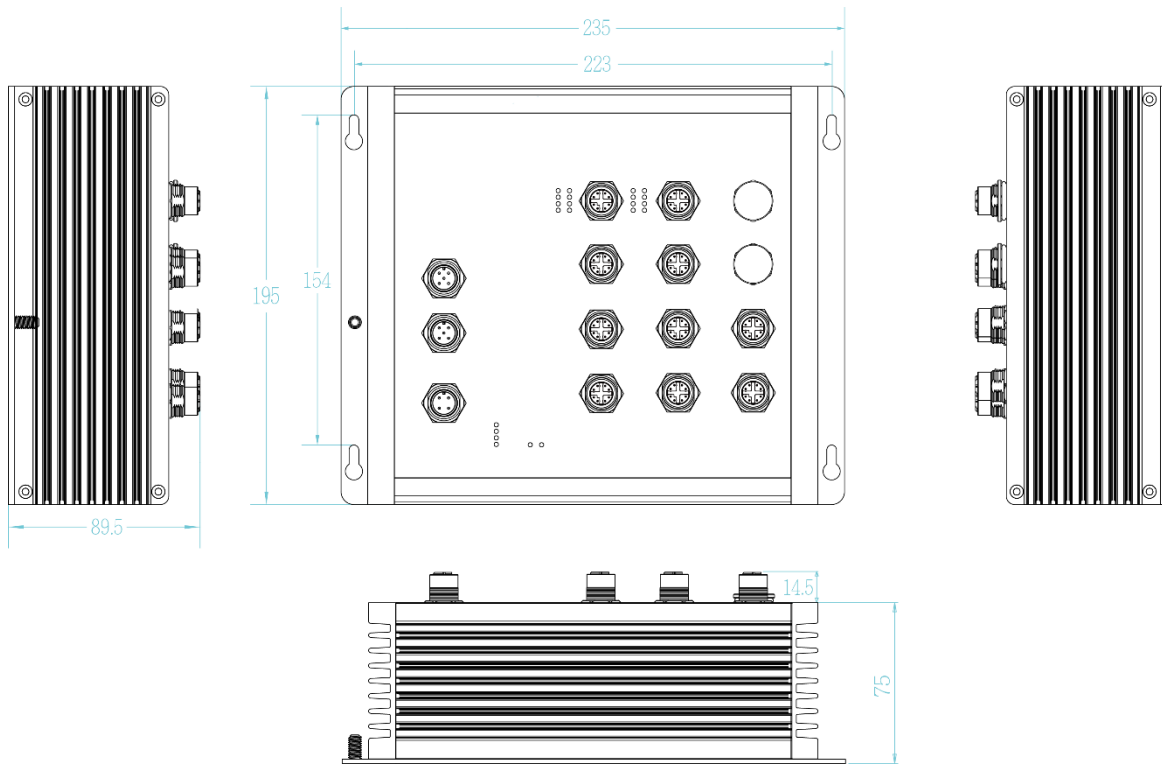

### T(P)GS-5008T

Aluminum case. IP-54, 235mm (W) x 195mm (H) x 89.5mm (D)

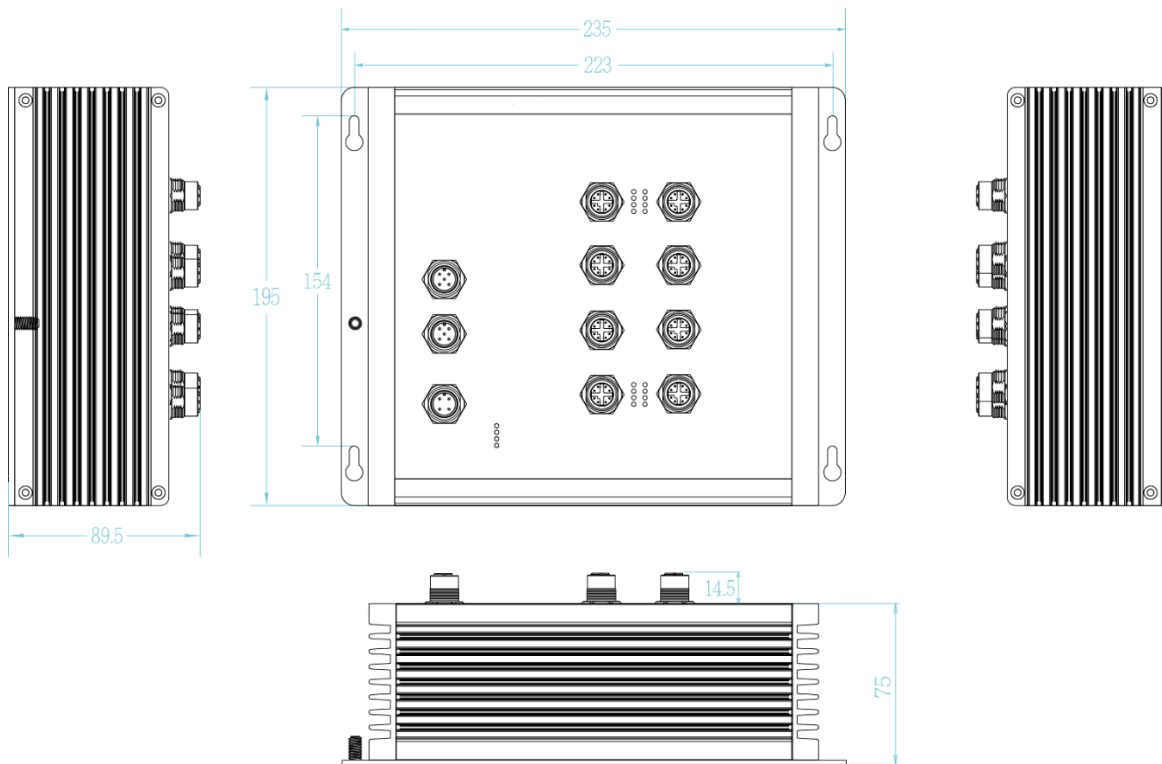

# Port description of T(P)GS-5208GF

(For TGS-5208GF, there's no PoE icons and PoE LEDs)

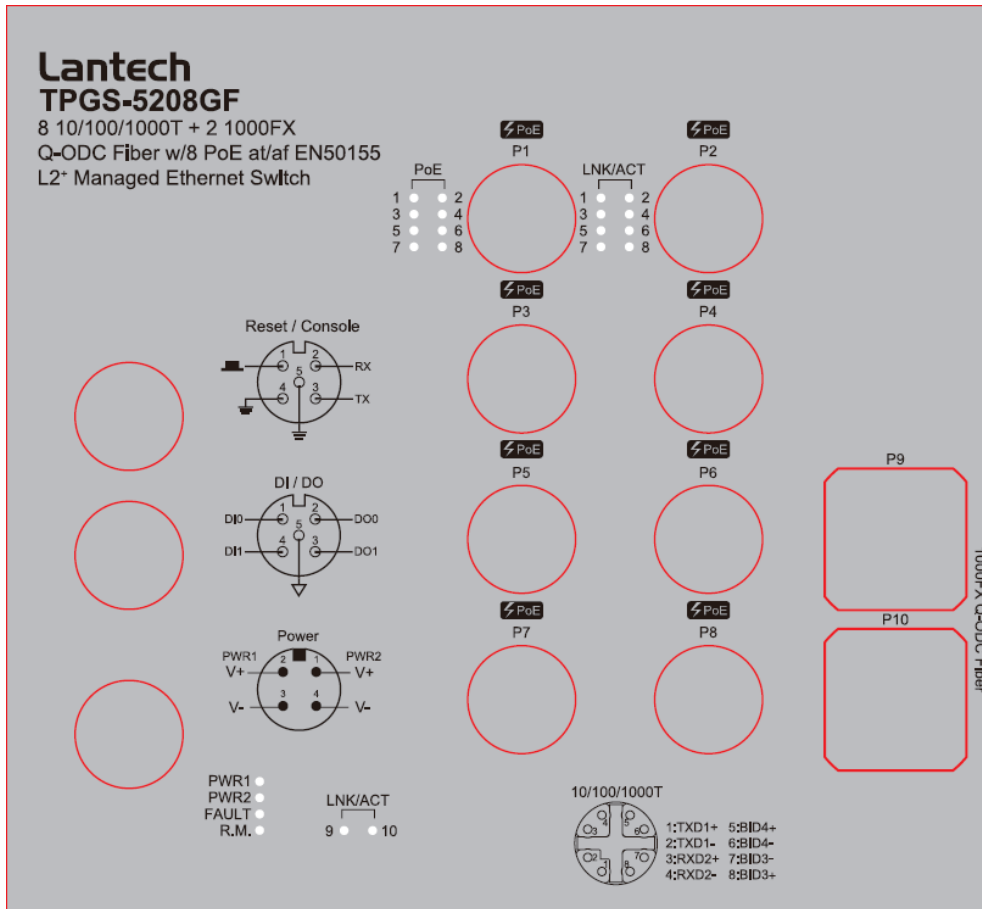

# Port description of T(P)GS-5010T

(For TGS-5010T, there's no PoE icons and PoE LEDs)

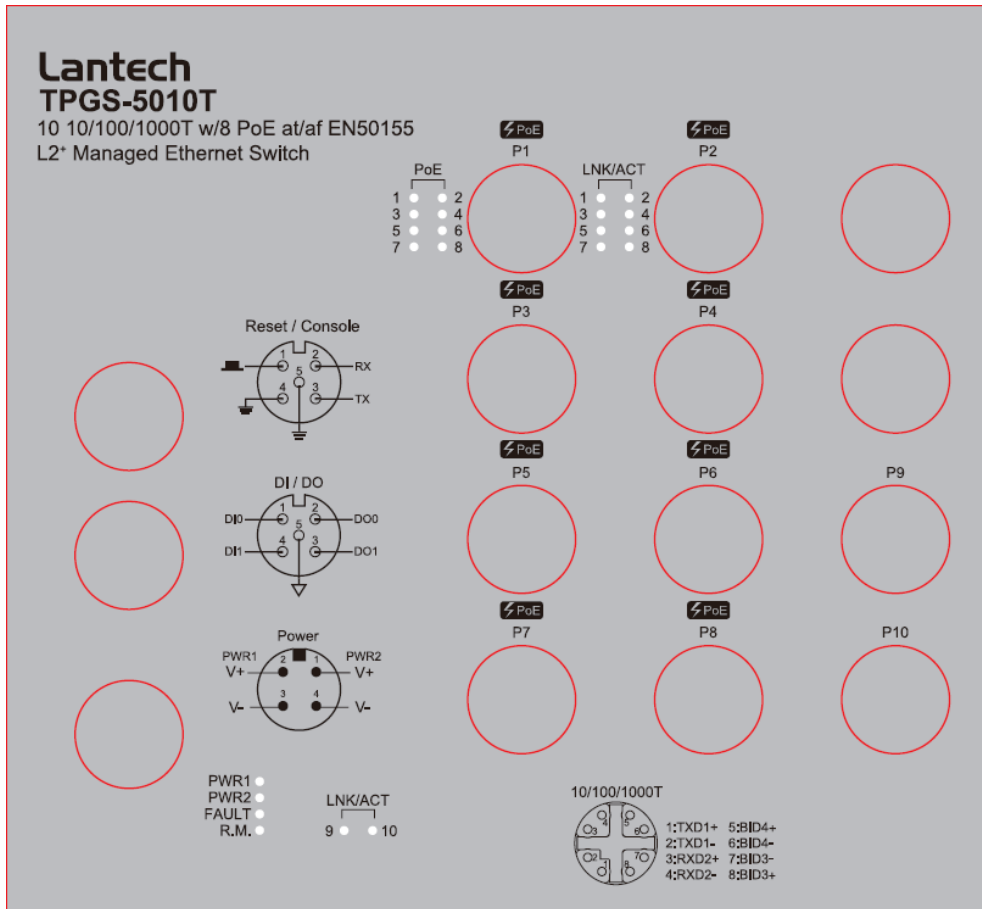

# Port description of T(P)GS-5008T

(For TGS-5008T, there's no PoE icons and PoE LEDs)

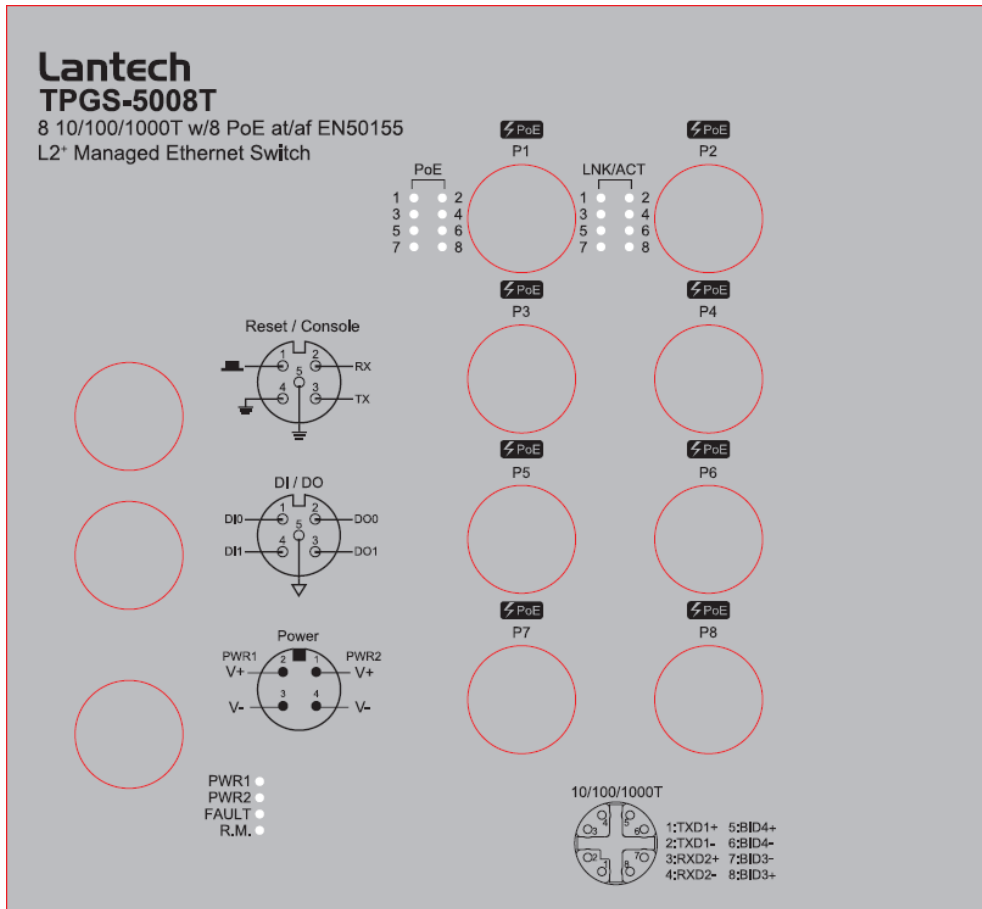

## **2.2 Package Content:**

- Manual CD (by request)
- Product
- Console cable

## 2.3 IP Protection

The **IP Code, Ingress Protection Rating**, sometimes also interpreted as **International Protection Rating**, classifies and rates the degree of protection provided against the intrusion (including body parts such as hands and fingers), dust, accidental contact, and water in *mechanical casings* and with electrical enclosures. It is published by the International Electrotechnical Commission (IEC)

Solid particle protection

The first digit indicates the level of protection that the enclosure provides against access to hazardous parts (e.g., electrical conductors, moving parts) and the ingress of solid foreign objects.

Level	Object size protected against	Effective against
0	—	No protection against contact and ingress of objects
1	>50 mm	Any large surface of the body, such as the back of a hand, but no protection against deliberate contact with a body part
2	>12.5 mm	Fingers or similar objects
3	>2.5 mm	Tools, thick wires, etc.
4	>1 mm	Most wires, screws, etc.
5	Dust protected	Ingress of dust is not entirely prevented, but it must not enter in sufficient quantity to interfere with the satisfactory operation of the equipment; complete protection against contact
6	Dust tight	No ingress of dust; complete protection against contact

## Liquid ingress protection

The second digit indicates the level of protection that the enclosure provides against harmful ingress of water.

<b>Level</b>	<b>Protected against</b>	<b>Testing for</b>	<b>Details</b>
<b>0</b>	Not protected	—	—
<b>1</b>	Dripping water	Dripping water (vertically falling drops) shall have no harmful effect.	Test duration: 10 minutes Water equivalent to 1 mm rainfall per minute
<b>2</b>	Dripping water when tilted up to 15°	Vertically dripping water shall have no harmful effect when the enclosure is tilted at an angle up to 15° from its normal position.	Test duration: 10 minutes Water equivalent to 3 mm rainfall per minute
<b>3</b>	Spraying water	Water falling as a spray at any angle up to 60° from the vertical shall have no harmful effect.	Test duration: 5 minutes Water volume: 0.7 litres per minute Pressure: 80–100 kPa
<b>4</b>	Splashing of water	Water splashing against the enclosure from any direction shall have no harmful effect.	Test duration: 5 minutes Water volume: 10 litres per minute Pressure: 80–100 kPa
<b>5</b>	Water jets	Water projected by a nozzle (6.3 mm) against enclosure from any direction shall have no harmful effects.	Test duration: at least 15 minutes Water volume: 12.5 litres per minute Pressure: 30 kPa at distance of 3 m

6	Powerful water jets	Water projected in powerful jets (12.5 mm nozzle) against the enclosure from any direction shall have no harmful effects.	Test duration: at least 3 minutes Water volume: 100 litres per minute Pressure: 100 kPa at distance of 3 m
7	Immersion up to 1 m	Ingress of water in harmful quantity shall not be possible when the enclosure is immersed in water under defined conditions of pressure and time (up to 1 m of submersion).	Test duration: 30 minutes Immersion at depth of at least 1 m measured at bottom of device, and at least 15 cm measured at top of device
8	Immersion beyond 1 m	The equipment is suitable for continuous immersion in water under conditions which shall be specified by the manufacturer. Normally, this will mean that the equipment is hermetically sealed. However, with certain types of equipment, it can mean that water can enter but only in such a manner that it produces no harmful effects.	Test duration: continuous immersion in water Depth specified by manufacturer
9	Powerful high temperature water jets	Protected against close-range high pressure, high temperature spray downs.	—



## 2.4 LED Indicators

The diagnostic LEDs that provide real-time information of system and optional status are located on the front panel of the industrial switch. The following table provides the description of the LED status and their meanings for the switch.

LED	Color	Status	Meaning
<b>R.M</b>	Green	On	The switch unit is owner switch of ITU-Ring
		Off	The switch is not owner switch
<b>PWR1</b>	Green	On	Power 1 is active
		Off	Power 1 is inactive
<b>PWR2</b>	Green	On	Power 2 is active
		Off	Power 2 is inactive
<b>FAULT</b>	Red	On	Power or port failure
		Off	No failure
<b>P1 ~ P8</b>	LNK/ACT	On	A network device is detected.
		Blinking	The port is transmitting or receiving packets from the TX device.
		Off	No device attached
	PoE (PoE models)	On	The port is operating in PoE mode.
		Off	The port is not operating in PoE mode.
<b>P9 ~ P10 (5010T)</b>	LNK/ACT	On	A network device is detected.
		Blinking	The port is transmitting or receiving packets from the TX device.
		Off	No device attached
<b>P9 ~ P10</b>	LNK/ACT	On	A network device is detected.

(5208GF)		Off	No device attached
----------	--	-----	--------------------

# Chapter 3 Hardware Installation

---



**For POE models: Do not use units' POE ports to uplink to another POE switch in vehicle applications. (May Cause Damage) Lantech strongly advise the installation of a Galvanic isolated DC/DC converter between the power supply and the Ethernet switch on all Non-Isolated models. Please contact the sales team for advice on which models support isolated power design.**

## **Alert! PoE Budget for Managed POE Switch Model**

For managed PoE models, the factory-default PoE budget is 12W per port; however, users can customize the PoE budget for each port based on their requirements. Managed switches have a safety feature where, if the total PoE budget is exceeded, the last connected port will automatically be disabled to prevent overloading.

Please be mindful of the total PoE budget limit. To prevent ports from shutting down due to insufficient budget, set the desired PoE budget for each used port and set the PoE budget for idle ports or ports that do not require PoE to "0". Once the preceding ports consume the entire PoE budget, the subsequent ports will not provide power for devices.

1. Unpack switch and check the accessory with packing content list
2. Mount the switch on desired position. For the best ventilation, it is suggested to mount the switch on metallic surface.
3. Connect the M12 connector of power input.

**Note:** Please check the power connector has been connected to the switch correctly before you turn on the power resource.

**Spec. of power input**

- Voltage of Power Input:  
Dual DC input, 16.8VDC~137.5VDC

- Total PoE budget: 80W

Please make sure that the external power supply unit can satisfy the total power consumption in field.

- Pin assignment of power input

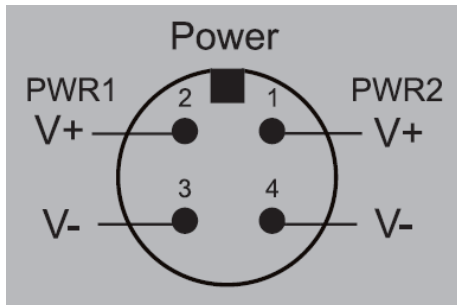

- Make sure the direction of connector is correct before you connect it.



- Plug power connector and screw in clockwise direction to fix it.



## ■ Dual Power Input

The power input can be supported redundantly. The supply voltage is electrically isolated from the housing.

**Note:** With single power supply of the mains voltage, the device will report a power failure. You can disable this power fail event via web browser.

**Attention:** When connecting to 110V DC power sources, the following scenarios can damage to the switch. Please avoid these scenarios.

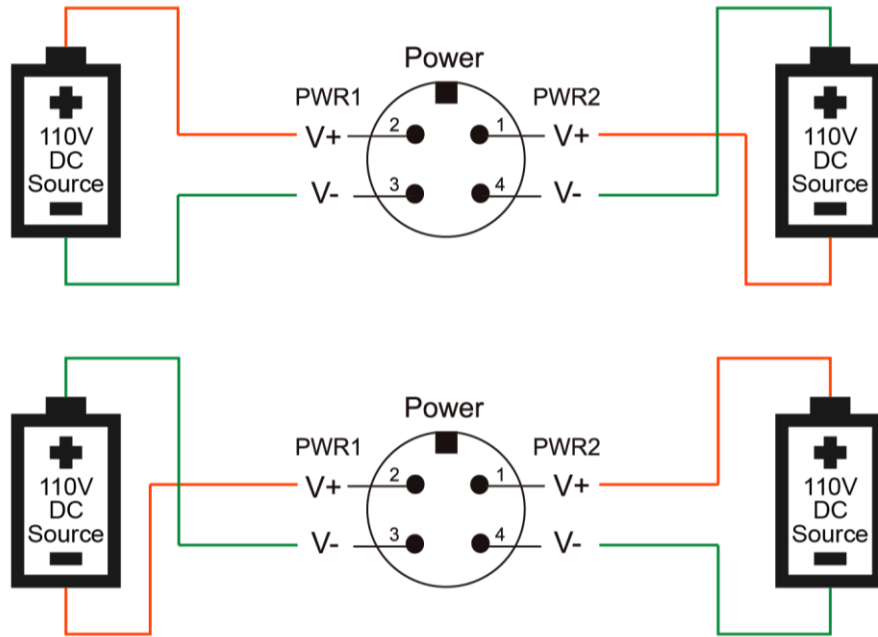

#### 4. Reset / Console

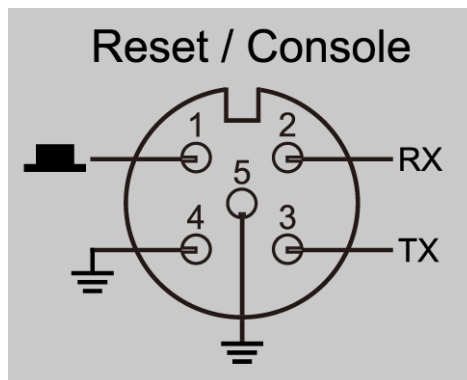

Pin assignment of reset function

Short the pin of reset with ground will reset system to factory default.

#### 5. DI /DO

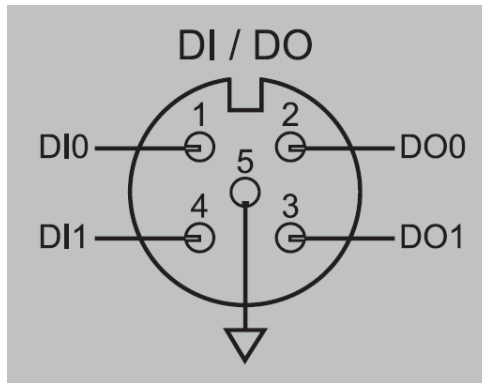

5.1 The DO of our switch will output 3.3V voltage if it is triggered.

5.2 The DI will be triggered with external 5VDC signal.

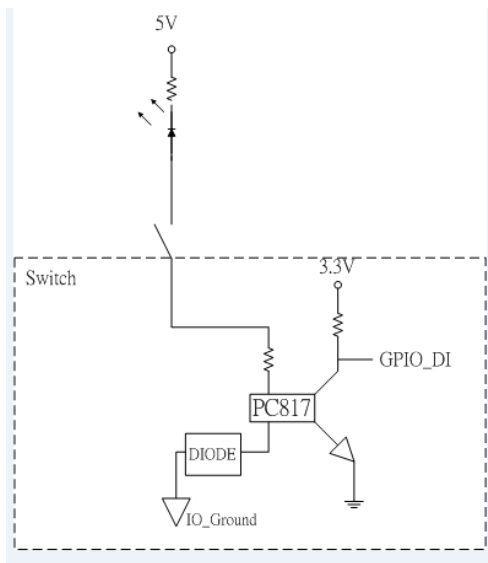

## 6. Fitting the device, grounding

Install the system in a dry and clean area to protect the switch to get exposed with dirt.

Plug the connector to the power supply plug then turn on the power supply.

### ■ Ground

The chassis is grounded via a separate grounding nut (M6).

Use toothed locking washers for a good electrical connection.

**\*Note: The torque should not be over 14 kilogram-force centimeter (kgf·cm). Using torque over 14 kgf·cm may cause damage to the**

grounding parts.



Ground screw of the switch

- Connect the M12 connector with RJ-45 data cable, ports are not used shall be capped that comes with the package to insulate the surrounding.

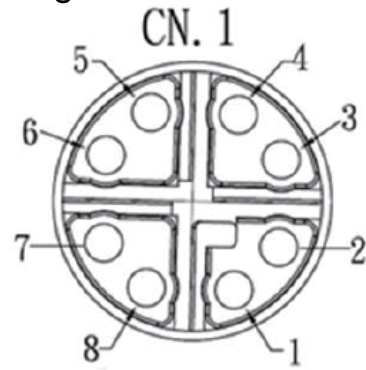
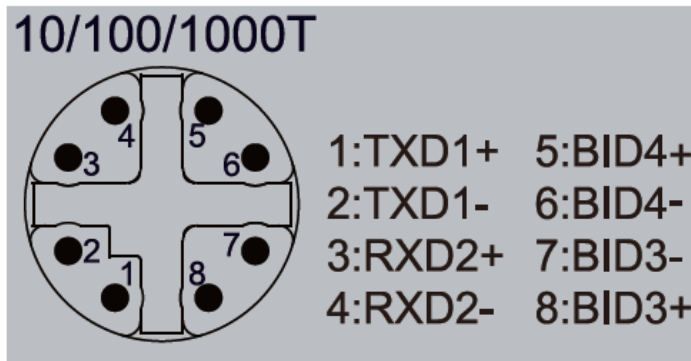

Switch connector <-----> Cable connector

Shell	Gnd	Shell	
1	Orange/ White	1	TWIST
2	Orange	2	
3	Green/ White	3	TWIST
4	Green	6	
5	Brown/ White	7	TWIST
6	Brown	8	
7	Blue/ White	5	TWIST
8	Blue	4	
CN. 1	Wire Color	CN. 2	
	PIN	OUT	

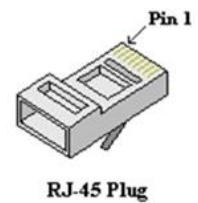
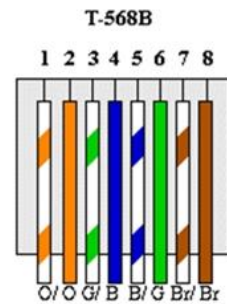



## Pin assignment of M12 10/100/1000T network connector

- Make sure the direction of connector is correct before you connect it.



- Plug 10/100/1000T connector and screw in clockwise direction to fix it.

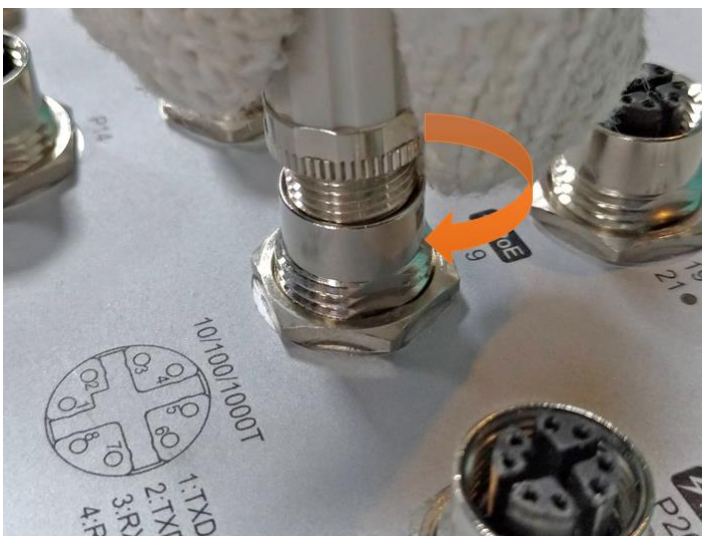
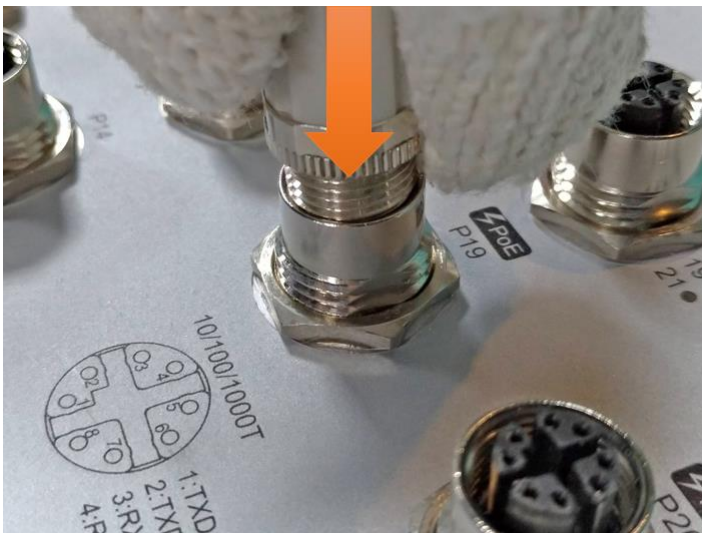

8. Connect the Q-ODC connector with Fiber cable, ports are not used shall be capped that comes with the package to insulate the surrounding.

- Make sure the direction of the connector is correct before you connect it.



- Plug 1000M connector and move in different directions to make sure the Q-ODC connector is correctly connected with the interface.

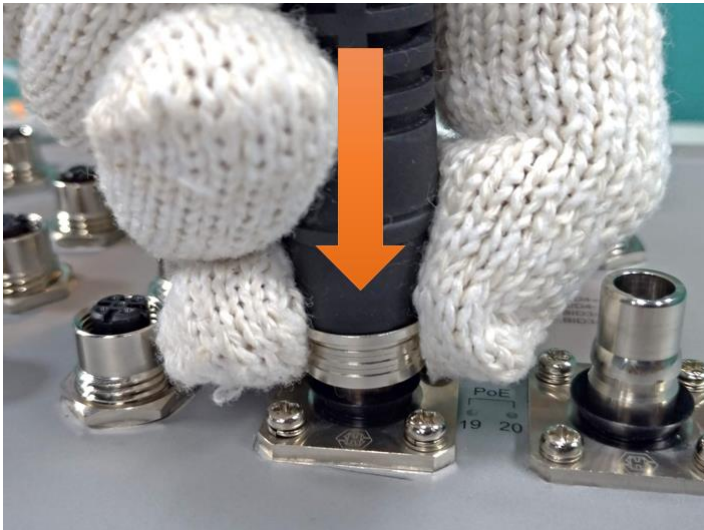

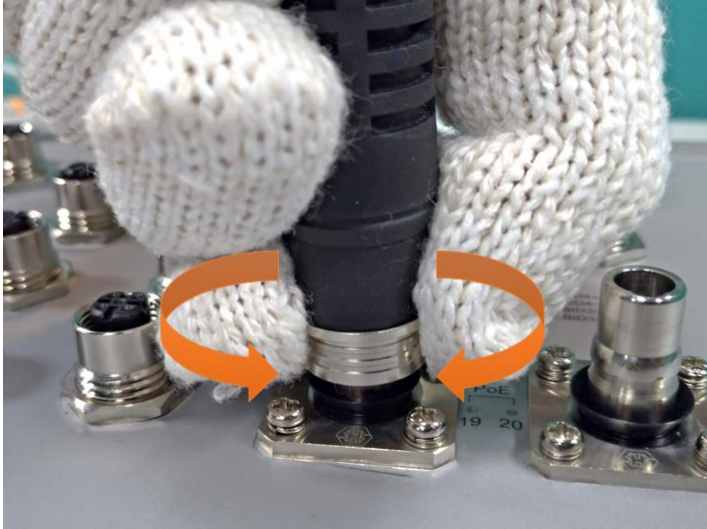

9. Check the status of LED, make sure the switch was in working status.

**Note:**

- The protection class IP54 is only achieved when bolted together.
- The other components attaching to the system have to meet with the IP54 protection class in order to reach the whole system IP54 protection.
- Empty ports must be sealed with the protective caps supplied.

# Chapter 4 Console Management

---

## 4.1. Connecting to the Console Port

The supplied cable which one end is M12 5-pole connector and the other end is RS-232 connector. Attach the end of RS-232 connector to PC or terminal and the other end of M12 connector to the console port of the switch. The connected terminal or PC must support the terminal emulation program.

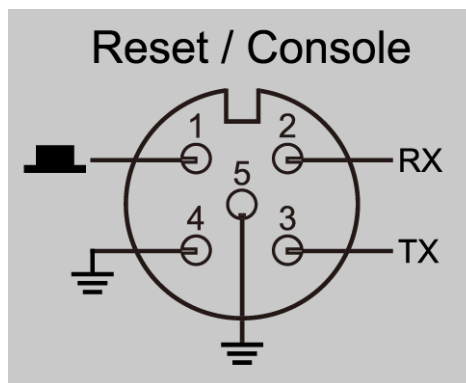

## 4.2. Login in the Console Interface

When the connection between Switch and PC is ready, turn on the PC and run a terminal emulation program or **Hyper Terminal** and configure its **communication parameters** to match the following default characteristics of the console port:

**Baud Rate: 115200 bps**

**Data Bits: 8**

**Parity: none**

**Stop Bit: 1**

**Flow control: None**

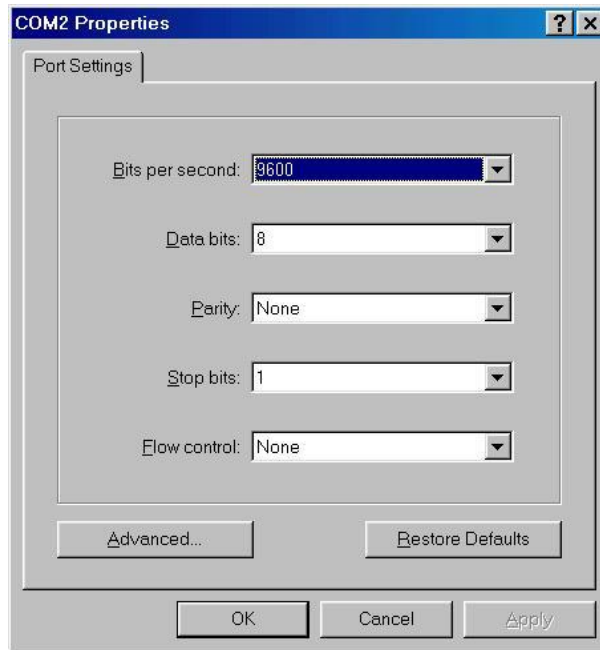

The settings of communication parameters

Having finished the parameter settings, click 'OK'. When the blank screen shows up, press Enter key to have the login prompt appears. Key in 'admin' (default value) for both User name and Password (use **Enter** key to switch), then press Enter and the Main Menu of console management appears. Please see below figure for login screen.

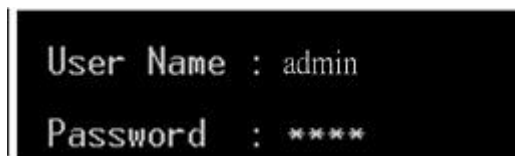

Console login interface

=====Notice=====

For web-based management, please refer to our "Software Management Manual".  
Please contact [support@lantechcom.tw](mailto:support@lantechcom.tw) for more information.