

Lantech

IPGS-0204G

**4 10/100/1000T + 2 Giga SFP Industrial
Switch w/4 PoE 802.3at Injectors**

User Manual



FCC Warning

This Equipment has been tested and found to comply with the limits for a Class-A digital device, pursuant to Part 15 of the FCC rules. These limits are designed to provide reasonable protection against harmful interference in a residential installation. This equipment generates, uses, and can radiate radio frequency energy. It may cause harmful interference to radio communications if the equipment is not installed and used in accordance with the instructions. However, there is no guarantee that interference will not occur in a particular installation. If this equipment does cause harmful interference to radio or television reception, which can be determined by turning the equipment off and on, the user is encouraged to try to correct the interference by one or more of the following measures:

- Reorient or relocate the receiving antenna.
- Increase the separation between the equipment and receiver.
- Connect the equipment into an outlet on a circuit different from that to which the receiver is connected.
- Consult the dealer or an experienced radio/TV technician for help.

CE Mark Warning

This is a Class-A product. In a domestic environment this product may cause radio interference in which case the user may be required to take adequate measures.

Content

Introduction	1
Features	1
Package Contents	2
Hardware Description	3
Physical Dimensions	3
LED Indicators.....	4
RJ-45 Pin Assignments	5
Installation	8
DIN-Rail Mounting.....	8
Wall Mounting.....	10
Grounding the Industrial Switch.....	11
Wiring the Power Inputs	12
Wiring the Fault Alarm Contacts	13
Ethernet Cabling	14
Troubleshooting	17
Technical Specifications	18

Introduction

The High-Power PoE Industrial Switch is a cost-effective solution, which meets the high reliability requirements demanded by industrial applications. To solve the inconvenience of wall outlet access, the equipment is designed with power over Ethernet ports complying with the **IEEE 802.3at** standard, providing each PoE port up to **30 watts** for connected Powered Devices that need higher power consumption to receive power as well as data over the conventional RJ-45 cables.

Features

- System Interface/Performance
 - RJ-45 ports support Auto MDI/MDI-X Function
 - Embedded 4-port PoE Injection
 - Store-and-Forward Switching Architecture
 - Back-plane (Switching Fabric): 12Gbps
 - MAC Address Table with 8K entries
- Power Input
 - DC 48V (48 ~ 57V) Redundant Power Input
- Case/Installation
 - IP-30 Protection
 - Installation in a Pollution Degree 2 environment
 - DIN-rail and Wall mountings Design

Package Contents

Please refer to the package contents list below to verify them against the checklist.

- PoE Industrial Switch x 1
- User manual (CD-ROM) x 1
- Removable Terminal Block x 1
- Wall-mount Kit (2 wall-mount brackets with screws) x 1

Compare the contents of the industrial switch with the standard checklist above. If any item is damaged or missing, please contact the local dealer for service.

Hardware Description

In this paragraph, the Industrial switch's dimensions, definitions for LED indicators, cabling information, and wiring installation will be described.

Physical Dimensions

The PoE Industrial Switch dimensions (W x H x D) are 59.6mm x 152mm x 105mm as the figure shown below.

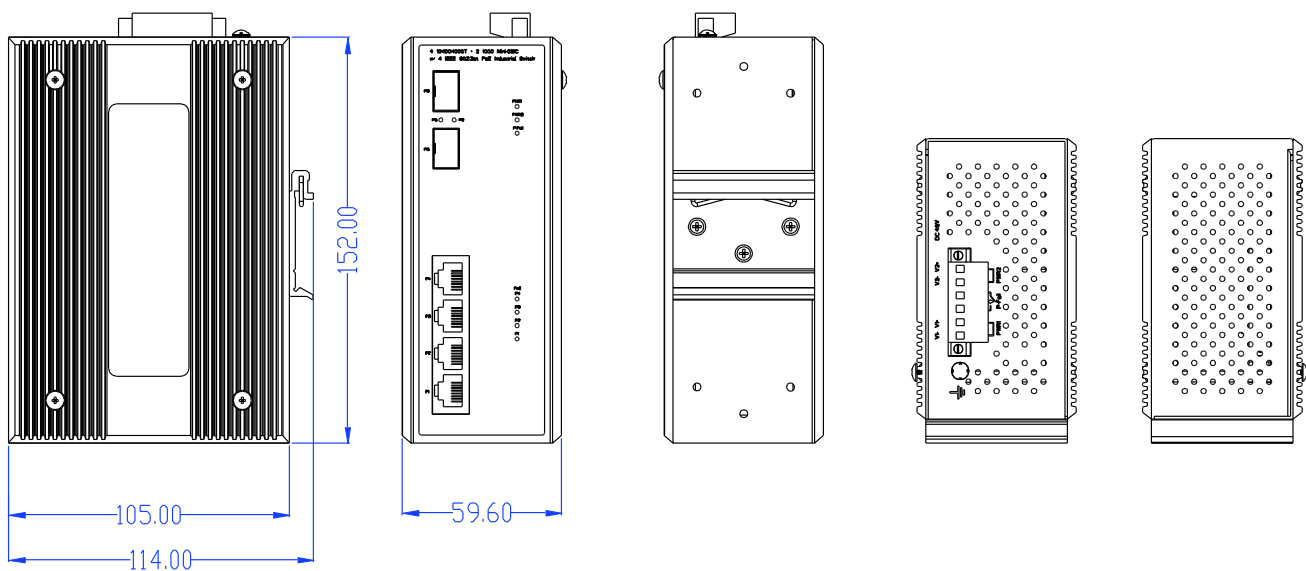

Side View

Front View

Rear View

Top View

Bottom View

LED Indicators

The diagnostic LED indicators located on the front panel of the industrial switch provide real-time system information and operation status. The table below provides the description status and definitions of the LED indicators for the switch.

LED	Color	Description	
Power1	Green	On	Power input 1 is active
		Off	Power input 1 is inactive
Power2	Green	On	Power input 2 is active
		Off	Power input 2 is inactive
P-Fail	Red	On	Power input 1 or 2 has failed
		Off	No failure occurs
PoE indicator (Port 1 ~ 4)	Green	On	The port is supplying power to the powered-device
		Off	No powered-device attached or power supplying fails
1 ~ 4 (RJ-45)	Green (upper)	On	Connected to network
		Flashing	Networking is active
		Off	Not connected to network
	Green (lower)	On	1000M
		Off	100/10M
5, 6 (mini-GBIC)	Green	On	Connected to network
		Flashing	Networking is active
		Off	Not connected to network

LED Indication Definition

RJ-45 Pin Assignments

The UTP/STP ports will automatically sense for Fast Ethernet (10Base-T/100Base-TX) or Gigabit Ethernet (10Base-T/100Base-TX/1000Base-T) connection. Auto MDI/MDIX means that the switch can connect to another switch or workstation without changing straight through or crossover cabling. See the figures below for straight through and crossover cable schema.

■ 10/100Base-TX Pinouts

Pin Number	Assignment
1	Tx+
2	Tx-
3	Rx+
6	Rx-

Note “+” and “-” signs represent the polarity of the wires that make up each wire pair.

The table below shows the 10Base-T/100Base-TX MDI and MDI-X port pinouts.

Pin Number	MDI-X Signal Name	MDI Signal Name
1	Receive Data plus (RD+)	Transmit Data plus (TD+)
2	Receive Data minus (RD-)	Transmit Data minus (TD-)
3	Transmit Data plus (TD+)	Receive Data plus (RD+)
6	Transmit Data minus (TD-)	Receive Data minus (RD-)

■ **10/100Base-TX Cable Schema**

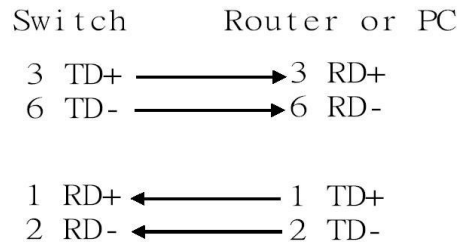

Straight Through Cable Schema

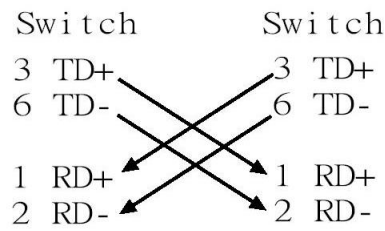

Crossover Cable Schema

■ **10/100/1000Base-T Pinouts**

The table below describes the gigabit Ethernet RJ-45 pinouts.

Pin	Signal name	Description
1	BI_DA+	Bi-directional pair A+
2	BI_DA-	Bi-directional pair A-
3	BI_DB+	Bi-directional pair B+
4	BI_DC+	Bi-directional pair C+
5	BI_DC-	Bi-directional pair C-
6	BI_DB-	Bi-directional pair B-
7	BI_DD+	Bi-directional pair D+
8	BI_DD-	Bi-directional pair D-

■ 10/100/1000Base-T Cable Schema

The following two figures illustrate the 10/100/1000Base-T cable schema.

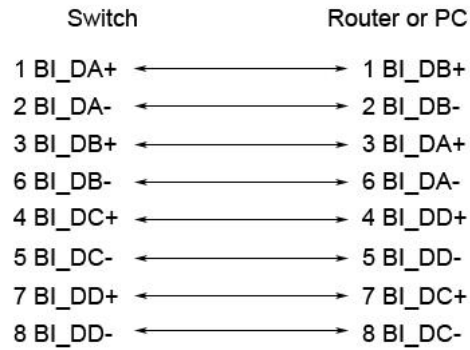

Straight Through Cable Schema

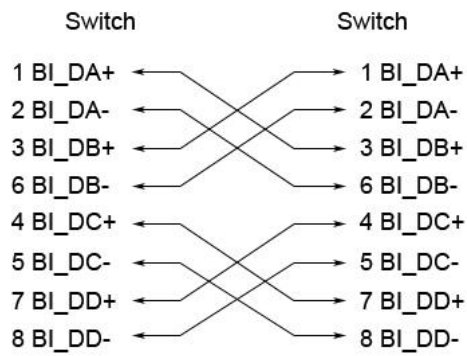

Crossover Cable Schema

Installation

ATTENTION

This equipment is intended for use in a Pollution Degree 2 industrial environment.



DIN-Rail Mounting

Assembling the DIN-Rail Clip

The DIN-rail clip is screwed on the industrial switch when out of factory. If not, please refer to the following steps to secure the DIN-rail clip on the switch.

1. Use the included screws to secure the DIN-rail clip on the industrial switch.
2. To remove the DIN-rail clip, reverse step 1.

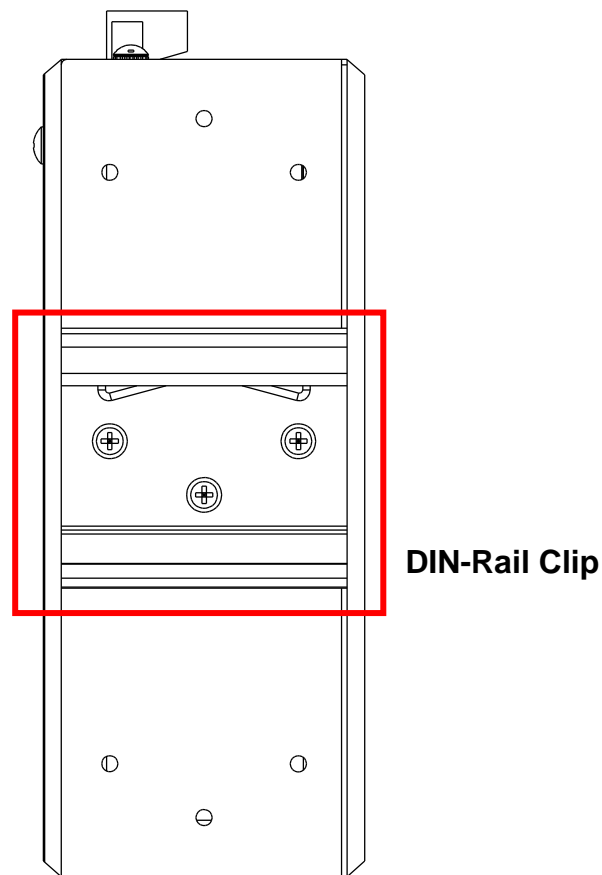

Rear side of the Switch

Hanging the Industrial Switch

Follow the steps below to hang the industrial switch on the DIN rail.

1. First, position the rear side of the switch directly in front of the DIN rail. Make sure the top of the clip hooks over the top of the DIN rail.

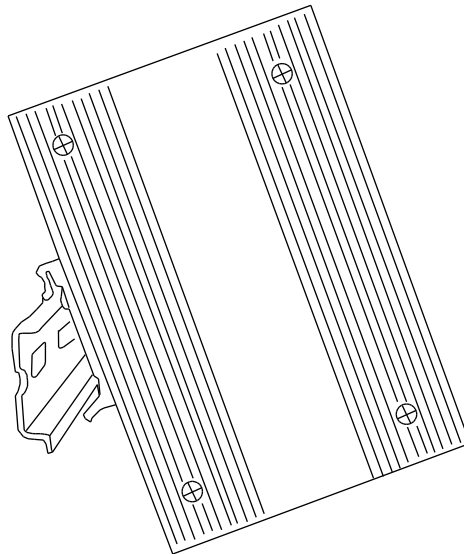

2. Push the unit downward.

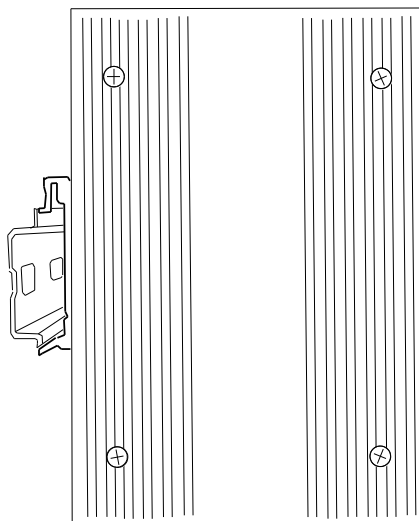

3. Check the DIN-Rail clip is tightly fixed on the DIN rail.
4. To remove the industrial switch from the track, reverse the steps above.

Wall Mounting

To hang the Ethernet switch on the wall, please follow the steps below.

1. Remove the DIN-rail clip.
2. Prepare the two wall-mount plates and six screws included.
3. Align the screw holes between the wall-mount plates and the unit as the figure illustrated.
4. Secure the plates to the unit with the accompanying screws.

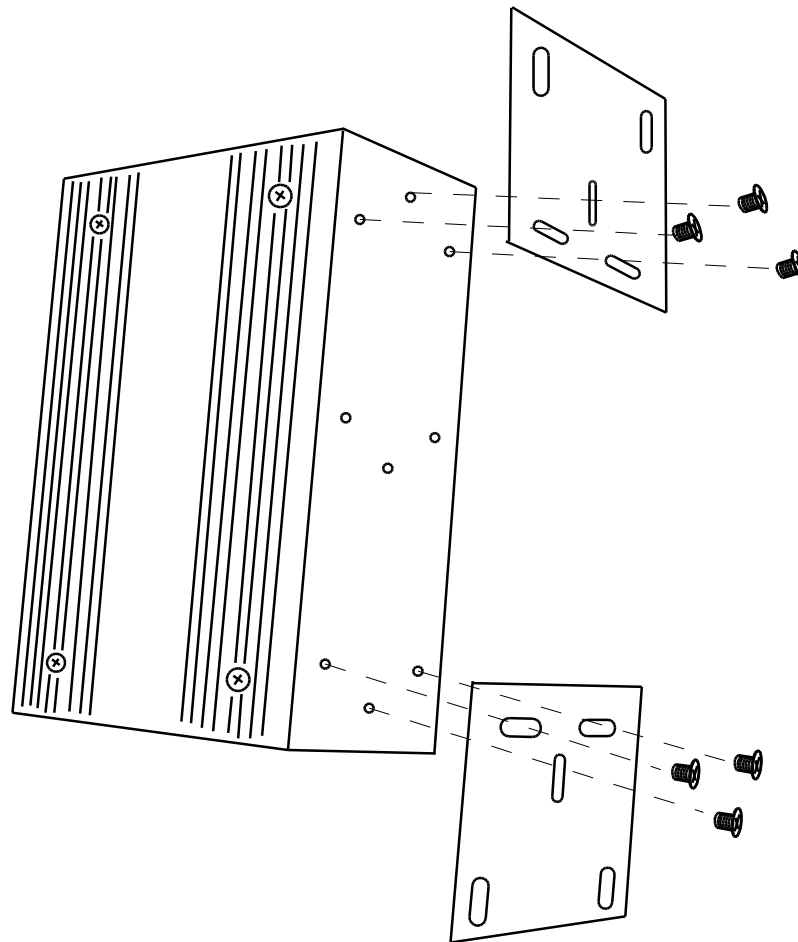

Grounding the Industrial Switch

Follow the instructions below to attach the industrial switch to ground.

ATTENTION



When installing the industrial switch, the ground connection must always be made first and disconnected last.

1. On the top of the industrial switch, locate and remove the dome screw which has a ground symbol beside it.
2. Attach the ground wire to the screw hole with the dome screw.

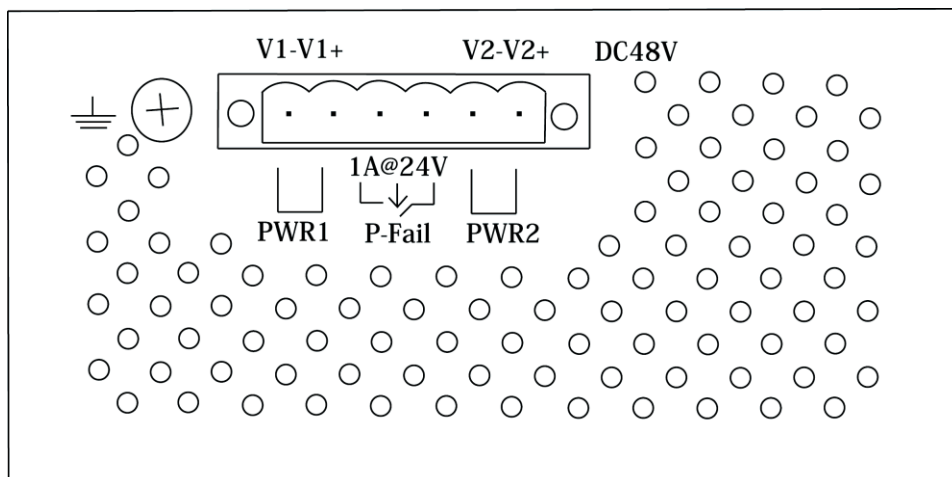

Wiring the Power Inputs

Please follow the steps below to wire power lines from the terminal block to the compliant external DC power source.

1. Before wiring, make sure the power source is disconnected.
2. Using the wire-stripping tool, strip a short piece of insulation from the output wires of the DC power source.
3. Identify the positive and negative feed positions for the terminal block connection. See the symbols printed on the panel indicating the polarities and DC input power range in voltage.

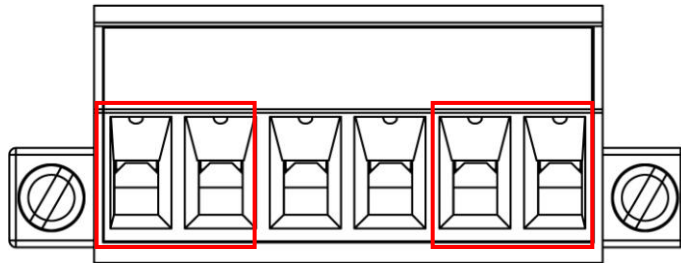

Plugs for Power 1 & Power 2

4. Insert the exposed wires into the terminal block plugs. Only wires with insulation should extend from the terminal block plugs. Note that the polarities between the wires and the terminal block plugs must be positive to positive and negative to negative.
5. Use a slotted screwdriver to tighten the captive screws.

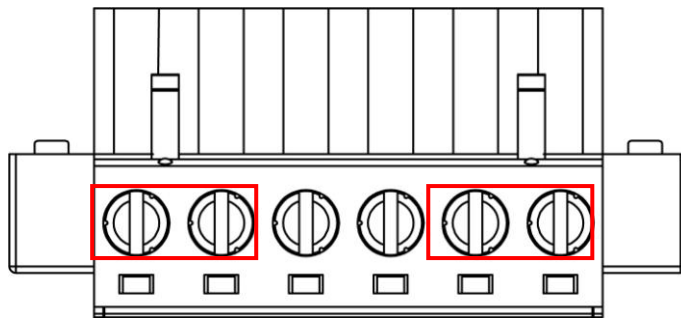

Captive Screws for Fixing Wires

ATTENTION



- Use Copper Conductors Only, **60/75°C**, tightening to **5 lb-in**
- The wire gauge for the terminal block should be in the range between **12~ 18 AWG**.

Wiring the Fault Alarm Contacts

The fault alarm plugs are in the middle of the terminal block, as the left picture shown below. With a **Normally Close** circuit formed by wiring with an external power and a warning device (a buzzer or a flashing LED), system will detect the fault status including the *port linking failure (managed industrial switch only)* and the *power failure*. Please refer to the right picture below, a wiring example for the fault alarm application.

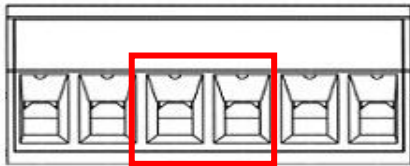

Terminal Block Plugs for Fault Alarm Contacts

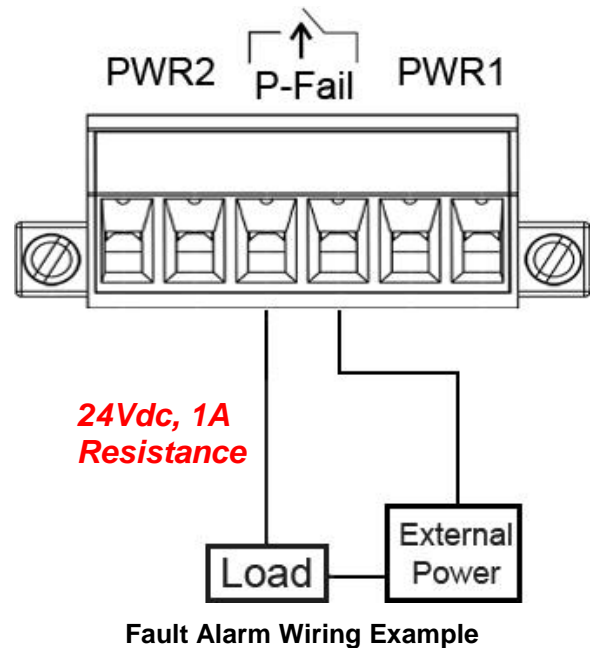

Ethernet Cabling

Use the four twisted-pair, Category 5e or above cabling for RJ-45 port connection. The cable between the switch and the link partner (switch, hub, workstation, etc.) must be less than 100 meters (328 ft.) long.

The small form-factor pluggable (SFP) is a compact optical transceiver used in optical communications for both telecommunication and data communication.

Connecting the SFP Port

To connect the transceiver and LC cable, please take the steps shown as follows:

First, insert the transceiver into the SFP slot. Notice that the triangle mark indicates the bottom of the slot.

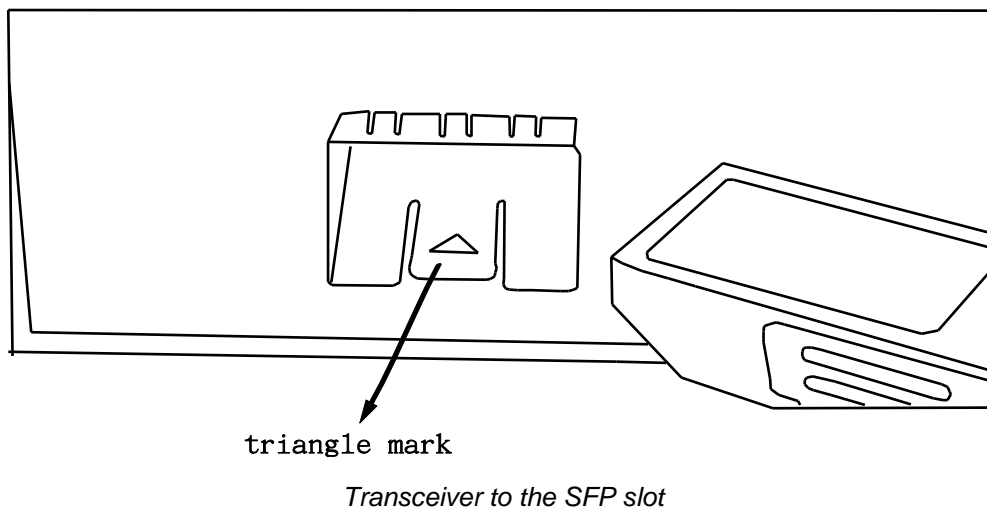

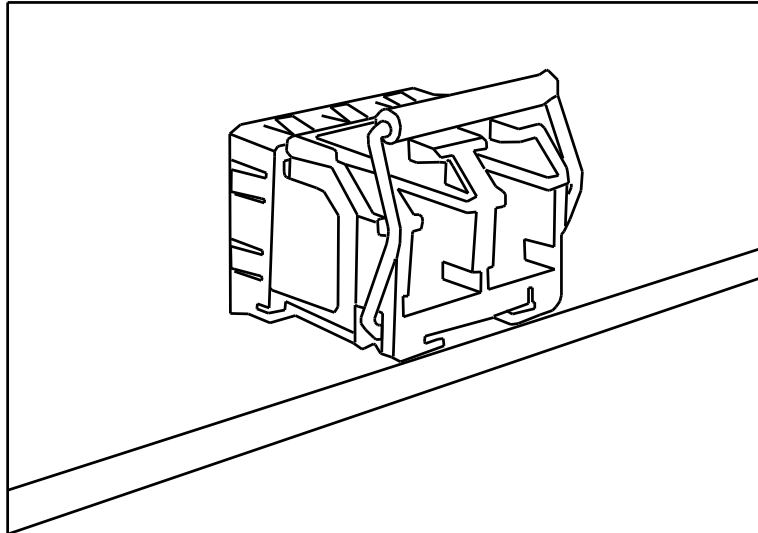

Transceiver Inserted

Second, insert the fiber cable of LC connector into the transceiver.

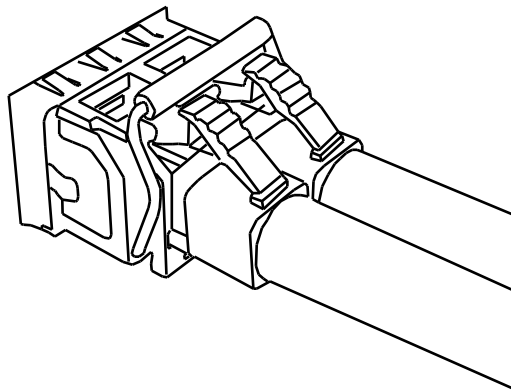

LC connected to the transceiver

Disconnecting the SFP Port

To remove the LC connector from the transceiver, please follow the steps shown below:

First, press the upper side of the LC connector from the transceiver and pull it out to release.

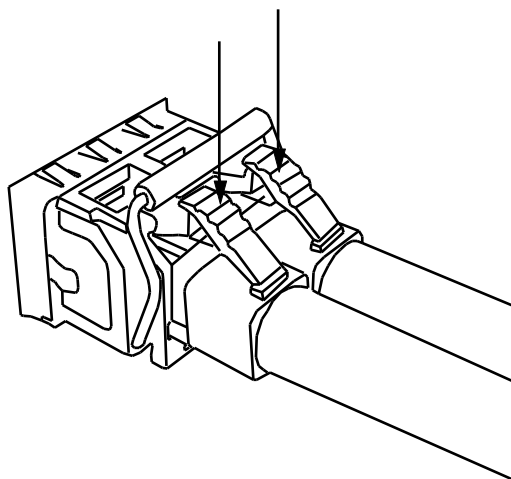

Remove LC connector

Second, push down the metal loop and pull the transceiver out by the plastic part.

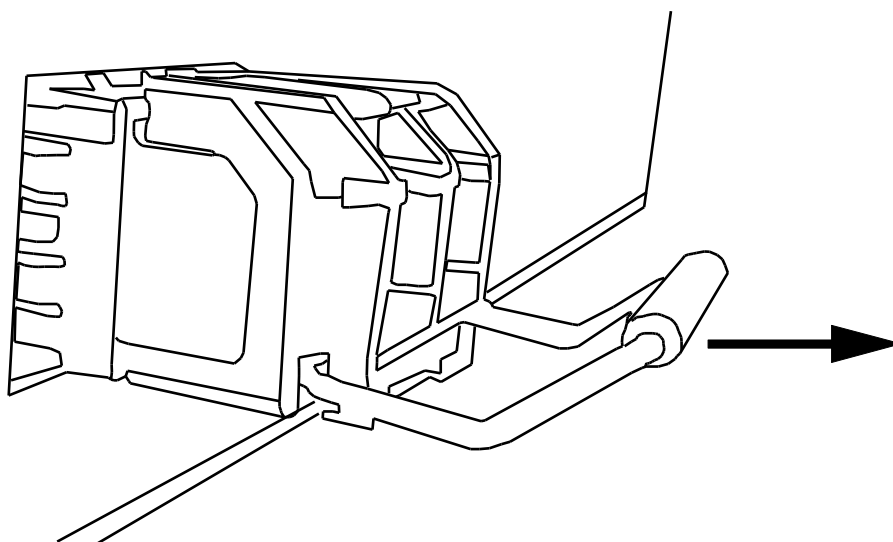

Pull out from the SFP slot

Troubleshooting

- Verify that you are using the included or appropriate power cord/supplier/adapter. Please don't use the power supplier/adapter with a non-compliant DC output voltage, or it will burn the equipment.
- Select the proper UTP/STP cable to construct your network. Please check that you are using the right cable. Use unshielded twisted-pair (UTP) or shield twisted-pair (STP) cable for RJ-45 connections: 100Ω Category 3, 4 or 5 cable for 10Mbps connections, 100Ω Category 5 cable for 100Mbps connections, or 100Ω Category 5e/above cable for 1000Mbps. Also be sure that the length of any twisted-pair connection does not exceed 100 meters (328 feet).
- **Diagnosing LED Indicators:** To assist in identifying problems, the Switch can be easily monitored through LED indicators on the front panel, which describe common problems the user may encounter and where the user can find possible solutions.
- If the power indicator does not light on when the power cord is plugged in, users may have a problem with the power cord. Then check for loose power connections, power losses or surges at power outlet. If you still cannot resolve the problem, contact the local dealer for assistance.
- If the Ethernet LED indicators are normal and the connected cables are correct but the packets still cannot transmit, please check your system's Ethernet devices' configuration or status.

Technical Specifications

Standard	<p>IEEE 802.3 10Base-T Ethernet</p> <p>IEEE 802.3u 100Base-TX Fast Ethernet</p> <p>IEEE 802.3ab 1000Base-T Gigabit Ethernet</p> <p>IEEE 802.3z 1000Base-X Gigabit Ethernet over Fiber-Optic</p> <p>IEEE802.3x Flow Control and Back Pressure</p> <p>IEEE802.3at Power over Ethernet</p>
Protocol	CSMA/CD
Switch Architecture	<p>Back-plane (Switching Fabric): 12Gbps</p> <p>Packet throughput ability (Full-Duplex): 17.85Mpps@64bytes</p>
Transfer Rate	<p>14,880 pps for Ethernet port</p> <p>148,800 pps for Fast Ethernet port</p> <p>1,488,000 pps for Gigabit Ethernet port</p>
MAC Address	8K-entry MAC address table
Connector	<p>10/100/1000Base-T: 4 x RJ-45</p> <p>1000Base-X: 2 x SFP</p>
PoE Pin Assignments	<p>RJ-45 port #1 ~ # 4 support IEEE 802.3at End-point, Alternative A mode. Each port provides 30W@55V power carrying ability.</p> <p>Positive (VCC+): RJ-45 pin 1, 2.</p> <p>Negative (VCC-): RJ-45 pin 3, 6.</p>
LED	<p>Per unit: Power 1 (Green), Power 2 (Green), P-Fail (Red)</p> <p>Ethernet: Link/Activity (Green), Speed (Green), mini-GBIC: Link/Activity (Green), PoE (Green)</p>

Network Cable	<p>10Base-T: 2-pair UTP/STP Cat. 3, 4, 5, 5e, 6 cable EIA/TIA-568 100-ohm (100m)</p> <p>100Base-TX: 2-pair UTP/STP Cat. 5, 5e, 6 cable EIA/TIA-568 100-ohm (100m)</p> <p>1000Base-T: 2-pair UTP/STP Cat. 5E/6 or above cable EIA/TIA-568 100-ohm (100m)</p>
Power Supply	DC 48V (48~57V), redundant power with polarity reverse protection
Power Consumption	129.9W
Installation	DIN-Rail mounting, Wall mounting
Operating Temp.	-40 to 75°C (-40 to 167°F)
Operating Humidity	5% to 95% (Non-condensing)
Storage Temp.	-40 to 85°C
Dimensions	IP-30, 59.6mm (W) x 152mm (H) x 105mm (D)
EMC	<p>FCC Class A</p> <p>CE EN61000-4-2/3/4/5/6/8</p> <p>CE EN61000-6-2</p> <p>CE EN61000-6-4</p>
Stability Testing	<p>IEC60068-2-32 (Free fall)</p> <p>IEC60068-2-27 (Shock)</p> <p>IEC60068-2-6 (Vibration)</p>