

# Lantech

---

## IPES-0008-M12

8 10/100TX IP41 rated Industrial Switch  
w/M12 connectors

User Manual



# Content

---

Overview .....	1
Introduction .....	1
Features .....	2
Technical Specification .....	3
Packing List.....	5
Safety Precaution .....	5
Hardware Description.....	6
Physical Dimensions .....	6
Front Panel.....	7
LED Indicators.....	8
Fast Ethernet Ports .....	9
Pinouts of the Power Connector .....	10
Power Restriction (under - 48VDC power).....	11
Installation .....	12
Wall Mounting .....	12
DIN-Rail Mounting.....	13
Grounding the Ethernet Switch .....	14

Troubleshooting .....	15
-----------------------	----

# Overview

---

## Introduction

The 8 10/100TX IP41 rated Industrial Switch w/M12 connectors and 4 PoE injectors is a rugged device to be deployed in various environments. The Ethernet switch conforms to EN50155, EN50121-3-2, EN50121-4 railway applications standards.

### Heavy Duty

Designed with circular M12 connectors and constructed with metallic housing, the Ethernet switch provides the rugged Fast Ethernet interface to withstand vibration and shock.

### Dual Power Inputs

The redundant power input design for the Ethernet switch gives a backup power solution. With both the power inputs supplied, if either one fails the other one will be activated to keep the systems operating continually.

### Flexible Mounting

The Ethernet switch is compact and can be mounted on the wall, and it is suitable for any space-constrained environment.

### Bypass Function

The equipment is designed with the function known as Bypass. When the power failure occurs, a shorted circuit between two Ethernet ports (P1 and P2) is formed to have the equipment being a bypassed device to prevent the network from disconnecting.

## Features

- Back-plane (switching fabric) : 1.6Gbps
- M12 connectors and IP41 metal housing
- Wide range redundant power design
- Wide operating temperature (-40~75°C)
- EN50155/50121-3-2/50121-4
- Auto Bypass between Port 1 and Port 2

# Technical Specification

## Communications

<b>Standard</b>	IEEE 802.3 10Base-T IEEE 802.3u 100Base-TX IEEE 802.3x Flow control and back pressure
<b>LAN</b>	10/100Base-TX
<b>Transmission Speed</b>	Up to 100 Mbps
<b>Switch Architecture</b>	Back-plane: 1.6Gbps
<b>Packet Buffer</b>	448Kbits
<b>MAC Address Table</b>	2K-entry

## Interface

<b>Connectors</b>	8 x M12, 4-pole D-coded, female (10/100TX) with the bypass function (P1 and P2) 1 x M12, 5-pole A-coded, male (Power)
<b>LED Indicators</b>	System: PWR1, PWR2 10/100Base-TX port: LNK/ACT

## Power

<b>Power Consumption</b>	3.36 Watts max. @ 48 V <sub>DC</sub>
<b>Power Input</b>	12 ~ 48 V <sub>DC</sub>

## Mechanism

<b>Dimensions (WxHxD)</b>	92 x 180 x 42 mm
<b>Enclosure</b>	IP41 protection, metal housing
<b>Mounting</b>	DIN-rail, Wall

## Environment

<b>Operating Temperature</b>	-40 ~ 75°C (-40 ~ 167°F)
<b>Operating Humidity</b>	5% ~ 95% (non-condensing)
<b>Storage Temperature</b>	-40 ~ 85°C (-40 ~ 185°F)

**Storage Humidity** 5% ~ 95% (non-condensing)  
**MTBF** 391, 306 hours

## Certifications

**Safety** UL, cUL 60950  
**EMC** CE, FCC Class A  
CE EN61000-4-2 (ESD)  
CE EN61000-4-3 (RS)  
CE EN61000-4-4 (EFT)  
CE EN61000-4-5 (Surge)  
CE EN61000-4-6 (CS)  
CE EN61000-4-8 (Magnetic Field)  
CE EN61000-6-2  
CE EN61000-6-4  
**Railway Traffic** EN50155, EN50121-3-2, EN50121-4  
**Free Fall** IEC60068-2-32  
**Shock** IEC61373  
**Vibration** IEC61373

## Packing List

- 1 x 8 10/100TX IP41 rated Industrial Switch w/M12 connectors and 4 PoE injectors
- 2 x Wall-mount plates with screws
- 1 x DIN-rail clip with screws
- 1 x User Manual (CD-ROM)

Compare the contents of the Ethernet switch with the standard checklist above. If any item is damaged or missing, please contact the local dealer for service.

## Safety Precaution

### **ATTENTION**



*IF DC voltage is supplied by an external circuit, please use a protection device on the power supply input.*

# Hardware Description

This section is intended to introduce the Ethernet switch's dimensions, definitions of LED indicators, and connector pinouts.

## Physical Dimensions

The figure below illustrates the dimensions for the Ethernet Switch.

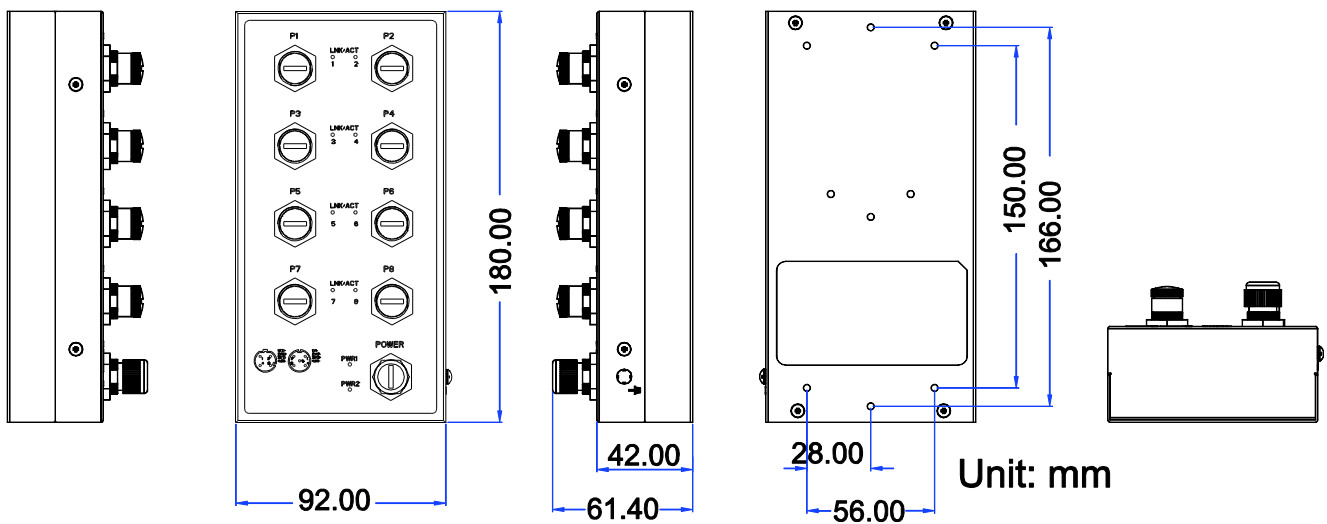

Mechanical Dimensions

# Front Panel

The figure shown below is the Front Panel of the Ethernet switch.

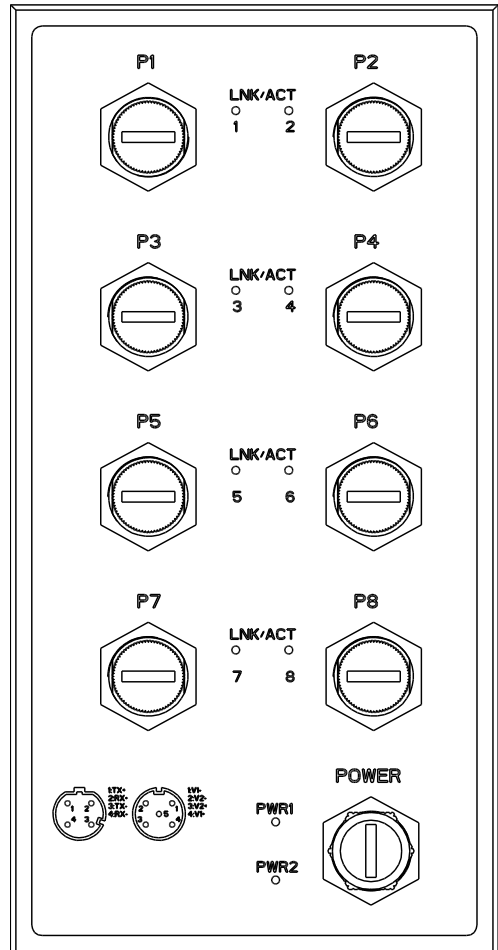

Front Panel

## LED Indicators

LED indicators located on the front panel display the status of system power, networking and power feeding over Ethernet of the Ethernet switch. Please refer to the following table for further details.

LED	Color	Description	
PWR1	Green	On	Power input 1 is active
		Off	Power input 1 is inactive
PWR2	Green	On	Power input 2 is active
		Off	Power input 2 is inactive
LNK/ACT	Green	On	Connected to network
		Blinks	Data is transmitting/receiving
		Off	Not connected to network

**Definition of LED indicators**

## Fast Ethernet Ports

Prepare the M12, 4-pole D-Coded Fast Ethernet Port mating cable for Ethernet connection. The M-12 D-coded Fast Ethernet ports are auto-sensing for 10Base-T or 100Base-TX devices connections. Auto MDI/MDIX means that you can connect to another switch or workstation without changing straight through or crossover cabling.

### ■ M12 D-coded Connector Pin Assignments

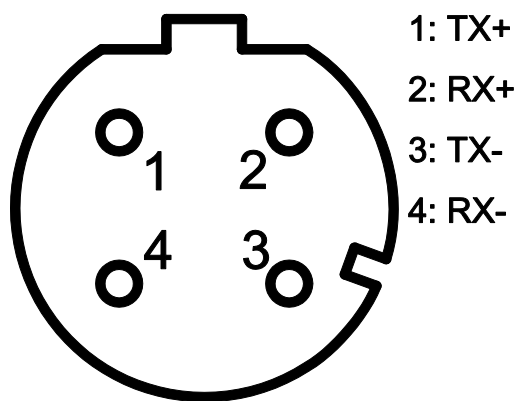

Pin Number	Assignments
1	Tx+
2	RX+
3	TX-
4	Rx-

*Note* “+” and “-” signs represent the polarity of the wires that make up each wire pair.

## Pinouts of the Power Connector

Prepare the M12, 5-pole A-Coded cable for Ethernet connection. Connect the positive and negative wires to **PWR1 (V1+, V1-)** and **PWR2 (V2+, V2-)** as the power pin assignments shown below.

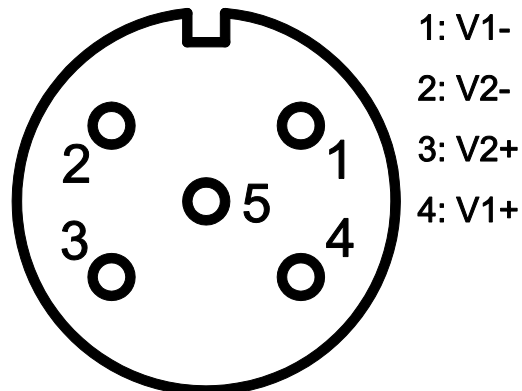

Power1 & Power2 Contacts of the M12 Connector

### Warning



*Only trained and qualified personnel should be allowed to install or replace this equipment.*

## Power Restriction (under - 48VDC power)

IPES-0008-M12 only can support one -48VDC power source. If using two -48VDC power source, IPES-0008-M12 may cause damage.

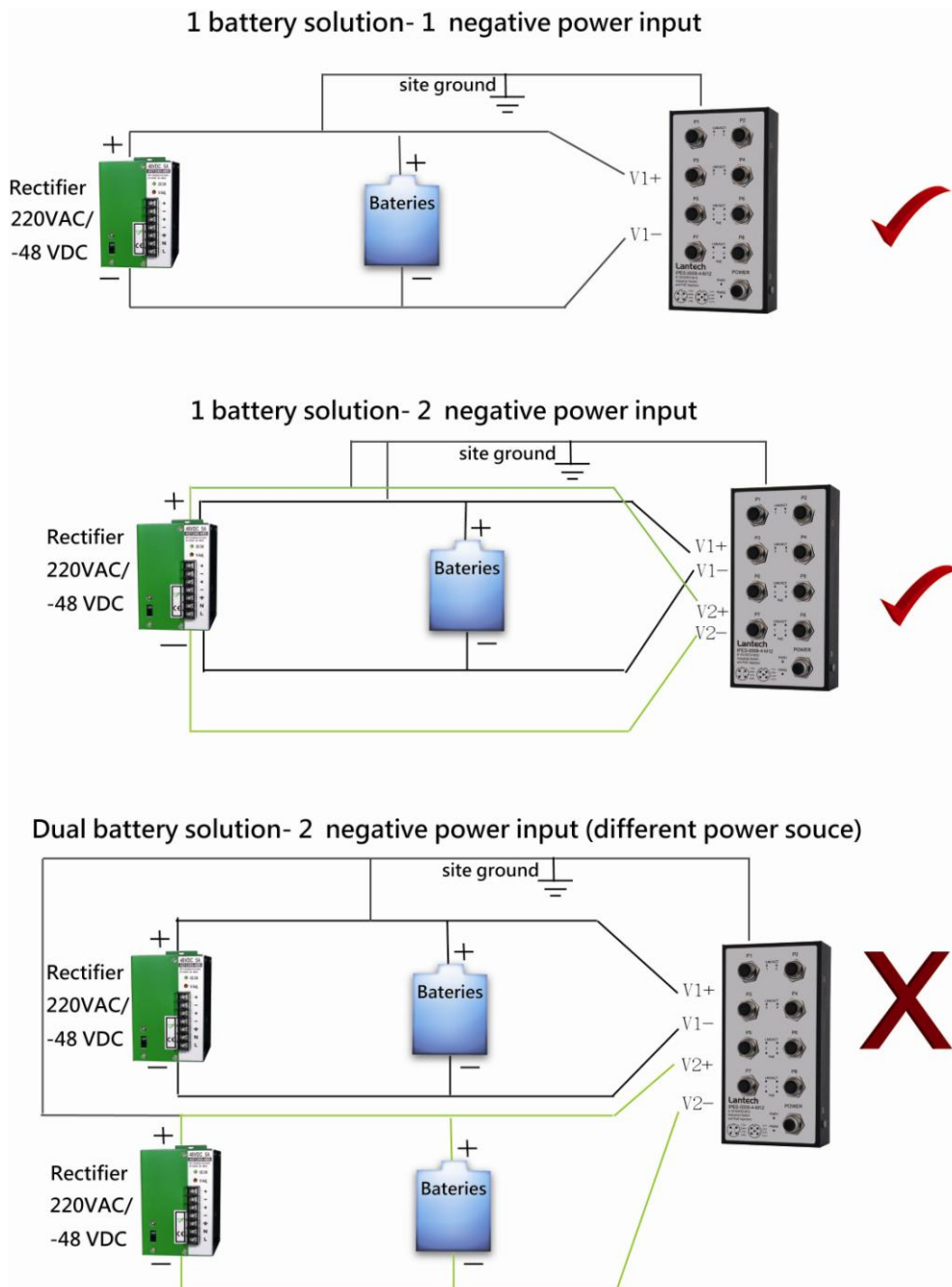

# Installation

---

## Wall Mounting

To hang the Ethernet switch on the wall, please follow the steps below.

1. Prepare the two wall-mount plates and six screws included.
2. Align the screw holes between the wall-mount plates and the unit as the figure illustrated.
3. Secure the plates to the unit with the accompanying screws.

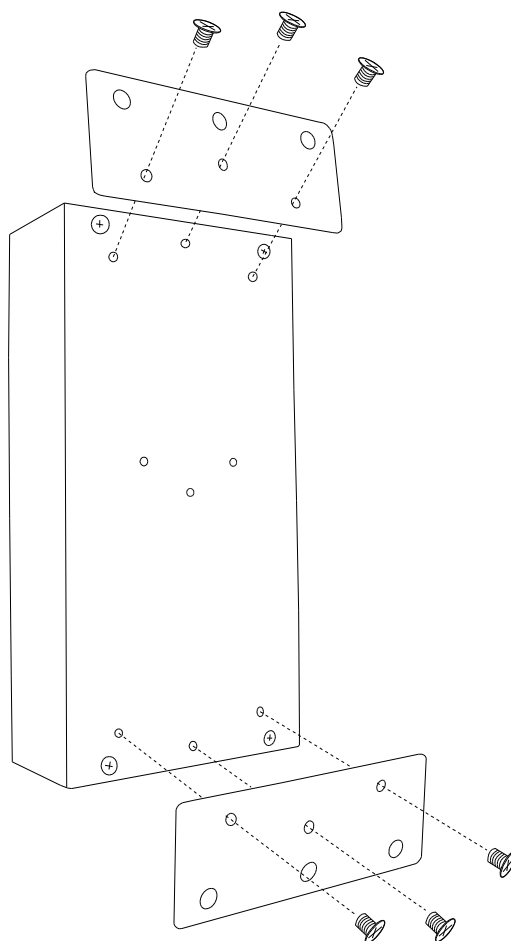

4. Having secured the plates to the unit, you can hang the Ethernet switch on something like nails sticking out from the wall.

## DIN-Rail Mounting

To mount the Ethernet switch to a standards DIN rail, please follow the steps below.

1. Prepare the DIN-rail clip and three screws included.
2. Align the screw holes between the clip and the unit as the figure illustrated.
3. Secure the DIN-rail clip to the unit with the accompanying screws.

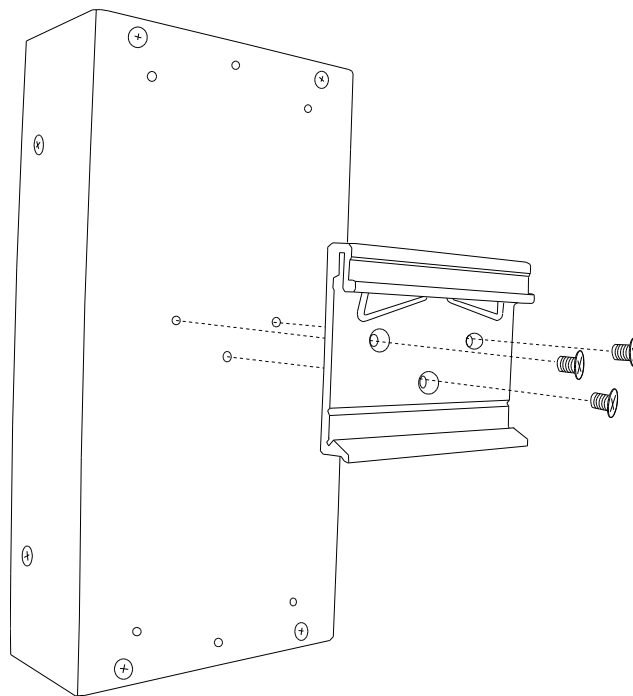

4. After you have secured the DIN-rail clip to the unit, position the clip side of the Ethernet switch directly in front of a standard DIN rail. Make sure the top of the clip hooks over the top of the DIN rail.

## Grounding the Ethernet Switch

Follow the instructions below to attach the Ethernet switch to ground.

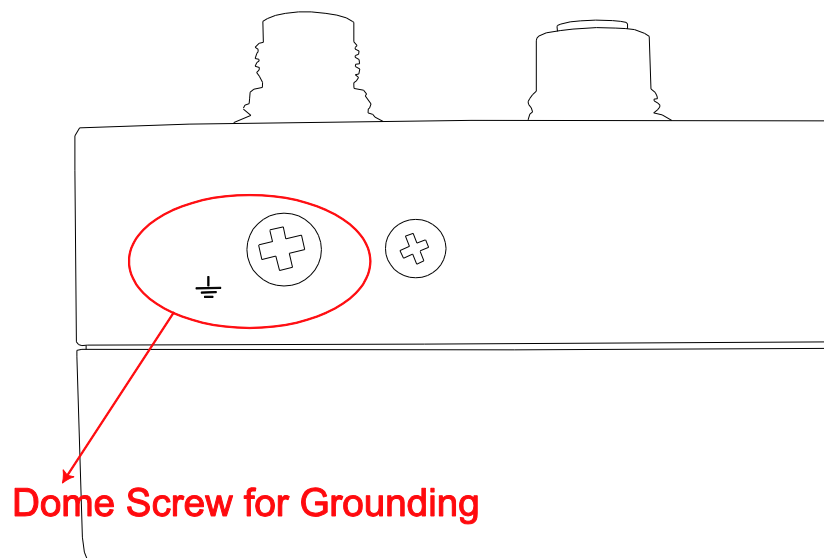

### **ATTENTION**



*When installing the Ethernet switch, the ground connection must always be made first and disconnected last.*

1. Locate and remove the dome screw which has a ground symbol beside it.
2. Attach the ground wire to the screw hole with the dome screw.

# Troubleshooting

---

- Verify that you are using the correct power cord/adapter. Don't use the power adapter with DC output higher than the rated voltage of the equipment. Or the equipment will be damaged.
- Select proper cables to construct your network. Please check that you are using the right cables.
- **Diagnosing LED Indicators:** the equipment can be easily monitored through panel indicators, which describes common problems you may encounter and where you can find possible solutions to assist in identifying problems.
- If the power indicator does not light up when the power cord is plugged in, you may have a problem with power cord. Then check for loose power connections, power losses or surges at power outlet. If you still cannot resolve the problem, contact your local dealer for assistance.
- If the LED indicators are normal while the corresponding cables are connected correctly but the networking is still inactive, please check your system's Ethernet devices' configuration or status.