

Mini-GBIC (SFP)

125Mbps, WDM1310~1550, Single Fiber Bi-directional SFP,

ONU Transceiver

- Distance: 20km, 40km, 60km, 80km
- Standard Operating Temperature: -10°C ~ 70°C
- Wide Operating Temperature: -40°C ~ 85°C



OVERVIEW

Lantech 125Mbps Bi-directional (BiDi) Small Form Factor Pluggable (SFP) transceiver module series is specifically designed for the high performance integrated duplex data link over a single optical fiber. These transceiver modules are compliant with the SFP Multisource Agreement (MSA). With the hot pluggability, these modules offer an easy way to be installed into

SFP MSA compliant ports at any time without the interruption of the host equipments operating online.

Lantech 125Mbps BiDi SFP transceiver module series using a long wavelength FP or DFB laser diode and enable data transmission up to 80km on a single-mode (9/125μm) optical fiber.

FEATURES & BENEFITS

- 125~155Mbps bi-directional single-fiber link
- Single LC receptacle
- 1310~1550nm FP/DFB transmitter
- 1310~1550nm PIN receiver
- 20km to 80km point-to-point transmission
- SFP Multi-Source Agreement compliant
- Serial ID functionality support
- Class 1 laser safety standard IEC 60825 compliant
- Low power dissipation

SPECIFICATION

Absolute Maximum Ratings

Parameter	Symbol	Min.	Max.	Unit	Note
Storage Temperature	Ts	-40	+85	°C	
Supply Voltage	Vcc	-0.5	4.0	V	
Storage Relative Humidity	RH	5	95	%	

Recommended Operating Conditions

Parameter	Symbol	Min.	Typ.	Max.	Unit	Note
Case Operating Temperature	Tc	-10 / -40		70 / 85	°C	1
Supply Voltage	VccT VccR	3.1	3.3	3.5	V	
Supply Current	ITX + IRX		150	300	mA	

Notes: 1. Standard Operating Temperature / Wide Operating Temperature (-E model)

Transmitter Electro-Optical Interface

Parameter	Symbol	Min.	Typ.	Max.	Unit	Note				
Transmitter Differential Input Voltage	TD +/-	400		2400	mV					
Tx Fault - High	VFault_H	2		VccT	V					
Tx Fault - Low	VFault_L	VeeT		VeeT+0.8	V					
Tx Disable - High	VDisable_H	2		VccT	V					
Tx Disable - Low	VDisable_L	VeeT		VeeT+0.8	V					
Optical Output Power	20km	WDM1310	-14		-8	dBm	1			
		WDM1550	-14		-8					
	40km	WDM1310	-8		0					
		WDM1550	-8		0					
	60km	WDM1310	-5		0					
		WDM1550	-5		0					
	80km	WDM1310	0		+5					
		WDM1550	0		+5					
	Optical Extinction Ratio	ER	9					dB		
	Center Wavelength	20km	WDM1310	1260	1310			1360	nm	
WDM1550			1480	1550	1580					
40km		WDM1310	1260	1310	1360					
		WDM1550	1480	1550	1580					
60km		WDM1310	1260	1310	1360					
		WDM1550	1480	1550	1580					
80km		WDM1310	1260	1310	1360					
		WDM1550	1480	1550	1580					
Spectral Width		20km	WDM1310			4	nm			
			WDM1550			3				
	40km	WDM1310			2.5					
		WDM1550			1					
	60km	WDM1310			2.5					
		WDM1550			1					
	80km	WDM1310			2.5					
		WDM1550			1					
	Optical Rise / Fall Timet	tr / tf			2	ns				

Notes: 1. Coupling into a 9/125µm single-mode fiber.

Receiver Electro-Optical Interface

Parameter	Symbol	Min.	Typ.	Max.	Unit	Note				
Receiver Differential Output Voltage	RD +/-	400		2000	mV					
Receiver Overload	20km	WDM1310	-3				1			
		WDM1550	-3							
	40km	WDM1310	0							
		WDM1550	0							
	60km	WDM1310	0							
		WDM1550	0							
	80km	WDM1310	0							
		WDM1550	0							
	Receiver Sensitivity	20km	WDM1310					-32	dBm	1
			WDM1550					-32		
40km		WDM1310			-34					
		WDM1550			-34					
60km		WDM1310			-34					
		WDM1550			-34					
80km		WDM1310			-34					
		WDM1550			-34					
Operating Center Wavelength		20km	WDM1310	1480		1580	nm			
			WDM1550	1260		1360				
	40km	WDM1310	1480		1580					
		WDM1550	1260		1360					
	60km	WDM1310	1480		1580					
		WDM1550	1260		1360					
	80km	WDM1310	1480		1580					
		WDM1550	1260		1360					
	Return Loss	RL	12			dB			3	
	Receiver Loss of Signal - TTL Low	20km	WDM1310			-32			dBm	
WDM1550					-32					
40km		WDM1310			-34					
		WDM1550			-34					
60km		WDM1310			-34					
		WDM1550			-34					
80km		WDM1310			-34					
		WDM1550			-34					
Receiver Loss of Signal - TTL High		PRX_LOSA	-45			dBm				
Receiver Loss of Signal - Hysteresis		PRX_LOSH	0.5			dB				

Notes: 1. With BER better than or equal to 1×10^{-10} , measured in the center of the eye opening with 125Mbps~155Mbps, PRBS 2²³-1
 2. With BER better than or equal to 1×10^{-12} , measured in the center of the eye opening with 125Mbps~155Mbps, PRBS 2⁷-1
 3. For 80km model, the return loss is 14 dB

MTBF

		60% Confidence Level, 25°C		90% Confidence Level, 25°C	
		MTBF	FIT	MTBF	FIT
20km	WDM1310	2532284	395	1012914	987
	WDM1550	2532284	395	1012914	987
40km	WDM1310	813526	1229	325410	3073
	WDM1550	813526	1229	325410	3073
60km	WDM1310	813526	1229	325410	3073
	WDM1550	813526	1229	325410	3073
80km	WDM1310	813526	1229	325410	3073
	WDM1550	813526	1229	325410	3073

DIMENSIONS (unit=mm)

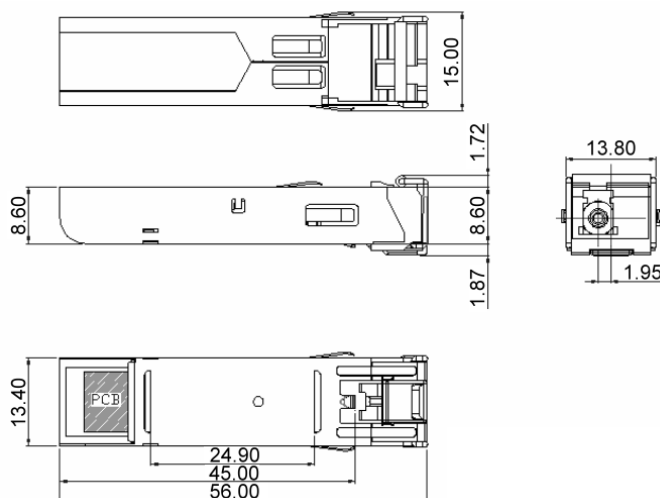

*All dimensions are ±0.2mm unless otherwise specified

ORDERING INFORMATION

Part Number	TX	LD	RX	IO	LOS	Link	Temp.
8330-069	1310nm	FP	1550nm	AC/AC	TTL	20km	-10° ~70°C
8330-069-E		FP				20km	-40° ~ 85°C
8330-080		FP				40km	-10° ~70°C
8330-080-E		FP				40km	-40° ~ 85°C
8330-081		FP				60km	-10° ~70°C
8330-081-E		FP				60km	-40° ~ 85°C
8330-084		FP				80km	-10° ~70°C
8330-084-E		FP				80km	-40° ~ 85°C

Part Number	TX	LD	RX	IO	LOS	Link	Temp.
8330-068	1550nm	FP	1310nm	AC/AC	TTL	20km	-10° ~70°C
8330-068-E		FP				20km	-40° ~ 85°C
8330-082		DFB				40km	-10° ~70°C
8330-082-E		DFB				40km	-40° ~ 85°C
8330-083		DFB				60km	-10° ~70°C
8330-083-E		DFB				60km	-40° ~ 85°C
8330-085		DFB				80km	-10° ~70°C
8330-085-E		DFB				80km	-40° ~ 85°C

Lantech Communications Global Inc.

www.lantechcom.tw
info@lantechcom.tw

© 2011 Copyright Lantech Communications Global Inc. all rights reserved.
The revise authority rights of product specifications belong to Lantech Communications Global Inc.
Lantech may make changes to specification and product descriptions at anytime, without notice.